

DC SERVO MOTORS

RX

0.3 to 8N.m

The RX DC motors, combined with RTS drives, provide an economical solution for any servo mechanism applications.

They are particularly suitable for low power systems in clean atmospheres.



RX characteristics

Motor	Torque at low speed M_0 (N.m)	Permanent current at low speed I_0 (A)	Rated voltage U (V)	Rated speed N (rpm)	Rotor inertia J ($\text{kgm}^2 \cdot 10^{-5}$)
RX120L	0.285	2.8	44.5	3000	5
RX130H	0.4	3.6	46	3000	6.8
RX320E	1.08	7.8	54	3000	50
RX330C	1.54	9.4	59	2900	72
RX520K	2.7	7.7	119	2800	128
RX530F	3.7	10.3	116	2700	174
RX620J	5	10.5	134	2400	350
RX630E	7.8	16	134	2400	500

Associated motor	Tachy		Brake (24Vdc $\pm 10\%$)			
	Type	EMF (V/1000 rpm)	Holding torque (N.m)		Inertia ($\text{kgm}^2 \cdot 10^{-5}$)	Weight (kg)
			at 20°C	at 100°C		
RX1	TBN 206	6	1	0.9	1	0.4
RX3	TBN 206	6	1.5	1.4	1	0.18
RX5	TBN 306	6	6	5.5	5.3	0.45
RX6	TBN 306	6	12	11.5	15.7	0.9

Encoder

Type	Associated motor	Pulses per rev.		Inertia ($\text{kgm}^2 \cdot 10^{-5}$)	Weight (kg)
		standard	option		
K10	RX1 / RX3	500	250	0.03	0.07
C4	RX1 / RX3	500	1000-2000	0.23	0.2
C6B	RX5 / RX6	500-1000	2500-5000	0.3	0.45

EXCELLENT PRICE/PERFORMANCE RATIO

VERY LOW TORQUE MODULATION

FERRITE MAGNETS

CONSTRUCTION QUALITY

VERY LONG LIFETIME

TACHY, ENCODER, RESOLVER OPTION

BRAKE OPTION

**PROTECTION IP40 (RX1 AND RX3)
IP54 (RX5 AND RX6), IP55 OPTION**

CLASS F INSULATION

DC SERVO MOTORS

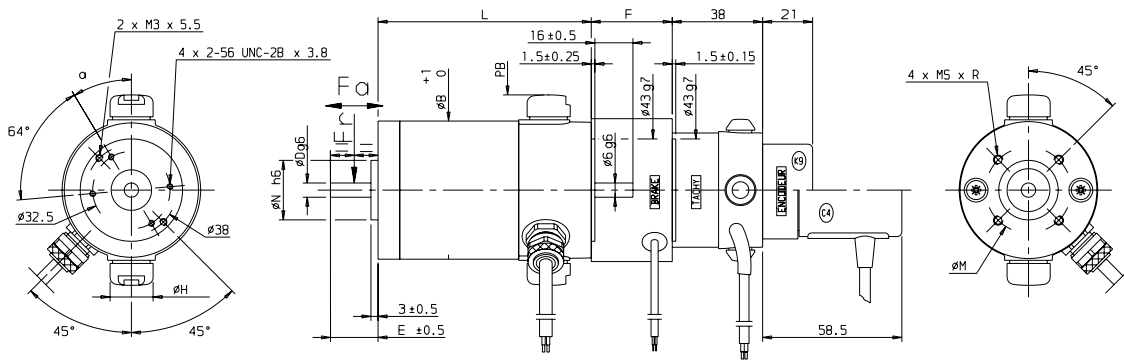

RX1 and RX3 with brake, tachy and encoder dimensions

Motor	H	α	N	D	E	B	PB	L	F	MSxR	M	Weight	Fr* (daN)	Fa* (daN)
RX120	18.5	31°	25	6	20	58	80	122.5	34	M4x6	36	1.35	18	16
RX130	18.5	31°	25	6	20	58	80	147.5	34	M4x6	36	1.6	20	16
RX320	23	26°	50	11	32	84	100	178.5	40	M5x10	65	4	45	23
RX330	23	26°	50	11	32	84	100	218.5	40	M5x10	65	5.2	50	23

*Fr and Fa not cumulative
Dimensions in mm
Weight in kg

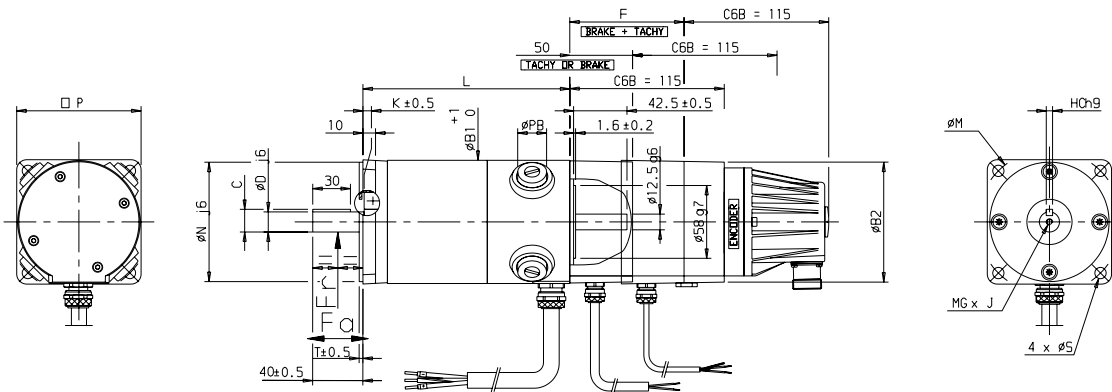

RX5 and RX6 with brake, tachy and encoder dimensions

Motor	P	N	C	D	T	K	B1	PB	L	F	B2	S	M	MGxJ	HC	Weight	Fr* (daN)	Fa* (daN)
RX520	100	95	18	16	3	1	98	25	216	91	96	9	115	M5x15	5	6.6	80	30
RX530	100	95	18	16	3	1	98	25	266	91	96	9	115	M5x15	5	8.7	85	30
RX620	120	110	21.5	19	3.5	0.5	116	30	272	93	117	10	130	M6x18	6	13	95	40
RX630	120	110	21.5	19	3.5	0.5	116	30	358	93	117	10	130	M6x18	6	18.5	100	40

*Fr and Fa not cumulative
Dimensions in mm
Weight in kg