

— TECO —
INVERTER

SPEECON
7200GS

(SENSORLESS VECTOR)

220V Class Three-phase (7.5~20) 25~100HP

440V Class Three-phase (7.5~20) 25~400HP

2003.10 By Y.F. FENG

Contents

1. Overview of 7200GS Series

2. 7200GS Inverter

a) MODEL DESIGNATION

b) SPECIFICATION

c) DIMENSIONS

d) INVERTER SERIES

e) CONNECTION DIAGRAM

3. Target Market

4. Sales Point

5. Product Comparison

a) The basic differences of 7200GS and 7200GA in H/W.

b) Comparison of 7200GS/ 7200GA/ 7200MA/ 7300PA in function.

c) Comparison of 7200GS/ 7200GA in parameter.

d) Rated current and carrier frequency.

e) Performance.

1. Overview of 7200GS Series

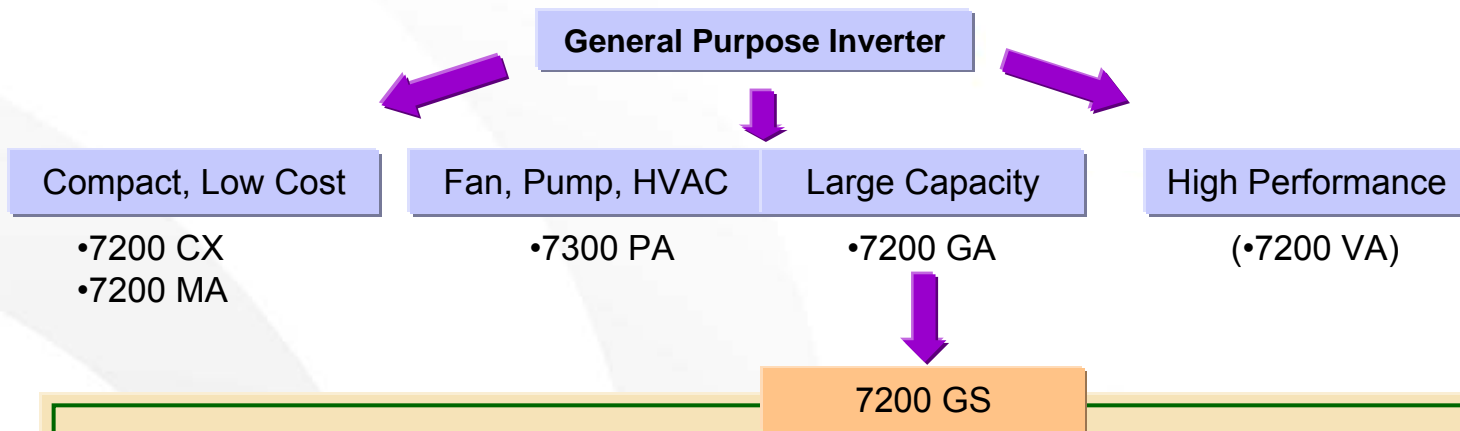

- * **Cost Down**
- * **Functions Upgrade :** Include all 7200GA'S features and add :
 - 1 > 4 in 1 function : V/F, V/F + PG (with FB - C Card),
PID & Auto Energy Saving. Sensorless (Auto tuning),
 - 2 > LCD Keypad (LED op : optional)
 - 3 > Output Zero phase filter built-in
 - 4 > New Generation IGBT (power loss , size , EMI)
- * **Completed Function :** 220V 3ø 25~100HP
440V 3ø 25~400HP
- * **Globalization :** CE, UL

2. 7200GS Inverter

a) MODEL DESIGNATION

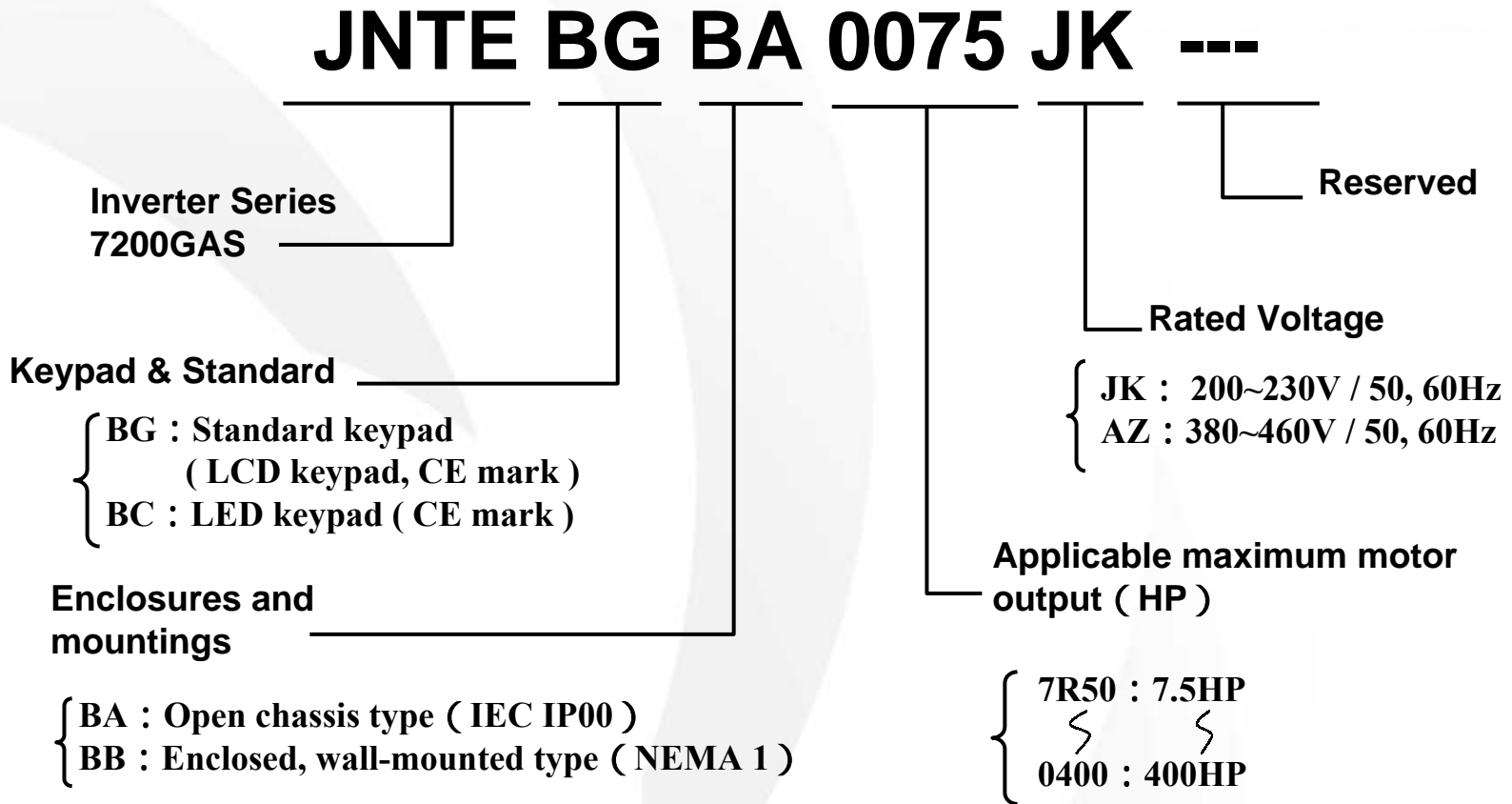

b) SPECIFICATIONS

● Performance Features

- **Ratings :** 25HP to 100HP at 230 VAC, 3ph
25HP to 400HP at 460 VAC, 3ph
- **Overload capacity :**
150% rated output current for 1 minute.
- **Control method :**
Sine wave PWM
Four control modes (Switched by parameter) :
 1. V/F control mode
 2. Sensorless vector control mode (with Auto-turning)
 3. PID & Auto Energy Saving mode
 4. V/F + PG Control mode
- **Speed Control range :** V/F Control 1 : 10
Sensorless Vector Control 1 : 60
- **Speed response :** 1 to 2 Hz (V/F Control)
5 Hz (Sensorless Vector)

b) SPECIFICATIONS

- **Speed control accuracy :**
 - V/F control : $\pm 1\%$ (with slip compensation)
 - V/F +PG control : $\pm 0.03\%$ (PG:1024ppr)
 - Sensorless Vector control : $\pm 0.5\%$
- **Starting torque :** 150% rated torque at 3Hz (V/F control)
150% rated torque at 1Hz (Sensorless Vector control)
- **Frequency Control range :** 0.1 ~ 400.0 Hz
- **Adjustable acceleration and deceleration :**
0.1 ~ 6000.0 sec (2 setting each, accel/ decel time setting independently)
- **Drive efficiency :** 96 to 98 %
- **Displacement power factor :** 0.98 through speed range
- **DC bus reactor :** 30HP to 250HP (for 460 VAC)
25HP to 100HP (for 230 VAC)
- **Power loss ride-thru :** 2 sec.
- **Selectable auto restart after momentary power loss.**

● Protective Features

- Current limited stall prevention during accel, decel and run.
- Overcurrent protection (OC) : 200% rated output current.
- Short circuit protection (SC) :
- Ground fault protection (GF) : approx. 50% of the inverter rated current.
- Motor overload protection (OL1) : Electronic thermal overload relay.
- Inverter overload protection (OL2) : Electronic thermal overload relay (150% inverte) rated current 1 minute
- Over torque protection (OL3)
- Overvoltage (OV) protection : 410 VDC (for 230VAC class)
820 VDC (for 460VAC class)
- Undervoltage (UV) protection : 190 VDC (for 230VAC class)
380 VDC (for 460VAC class)
- Synchronized start into rotating motor via speed search.

● Design Features

- LCD display (LED display : optional)
- Programmable digit output : One No. contact and two photo-coupler.
- Programmable digit input : 4
- Frequency setting signal : 0 ~ 10 VDC (20K Ω) , 4 ~ 20 mA (250 Ω)
- Multi-function analog input : 0 to 10 VDC (20 K Ω)
- Multi-function analog output : 0 to 10 VDC

- **RS-232 Communication port.**
- **Volts / hertz ratio :** programmable custom V/Hz pattern
- **Multi-speed settings :** 8 available

● **Environmental & Service Conditions**

- **Ambient service temperature :** -10 to +40 °C (for NEMA1 type)
-10 to +45 °C (for open classis type)
- **Humidity :** 0 to 95% relative humidity, non-condensing.
- **Location :** Indoor (protected from corrosive gases and dust)
- **Altitude :** to 3300 feet (1000 m)
- **Input voltage :** -15% / +10%, 200 to 230 VAC, 380 to 460 VAC
- **Enclosure :** IP00 and NEMA1

● **Options Available**

- **Input Fuses, Line Reactor, RFI filter, Braking resistor and Braking unit.**
- **Analog operator, digital operator extension cable.**
- **Interface options :**
RS-485 communication card (MODBUS and PROFIBUS), PG speed controller card, Digital pulse monitor card, Digital reference card, Analog reference card, Digital output card, 0-10/ 4-20mA conversion output card.

c) DIMENSIONS

Voltage (V)	Inverter Capacity (HP)	Open Chassis Type (IP00) mm						Weight (Kg)	Enclosed Type (NEMA1) mm						Weight (Kg)	ACL/DCL
		W	H	D	W1	H1	d		W	H	D	W1	H1	d		
220V	25	283.5	525	307	220	505	M8	30	291.5	745	307	220	505	M8	33	DCL Built-in (Standard)
	30															
	40	459	790	324.6	320	760	M10	75	462	1105	324.6	320	760	M10	81	
	50							76							82	
	60							79							85	
	75							79							88	
	100	599	1000	381.6	460	960	M12	120	602	1305	381.6	460	960	M12	130	
440V	25	265	360	225	245	340	M6	12	265	360	225	245	340	M6	12	External ACL (option)
	30	283.5	525	307	220	505	M8	36	291.5	745	307	220	505	M8	38	DCL Built-in (Standard)
	40							36							38	
	50	344	630	324.5	250	610	M8	47	352	945	324.5	250	610	M8	50	DCL Built-in (Standard)
	60							47							50	
	75							47							50	
	100							62							65	
	125	459	790	324.6	320	760	M10	80	462	1105	324.6	320	760	M10	85	DCL Built-in (Standard)
	150							81							86	
	175							81							86	DCL Built-in (Standard)
	215							599							1000	
	250	132	139													
	300	730	1230	382	690	930	M12		170	730	1330	382	690	930		M12
	400							190	196							

(a) 440V : 25HP

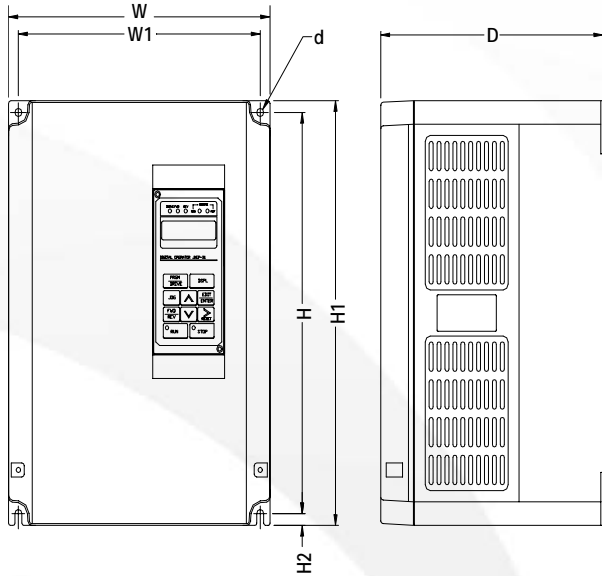

**(b) 220V : 25HP 100HP
440V : 30HP 250HP**

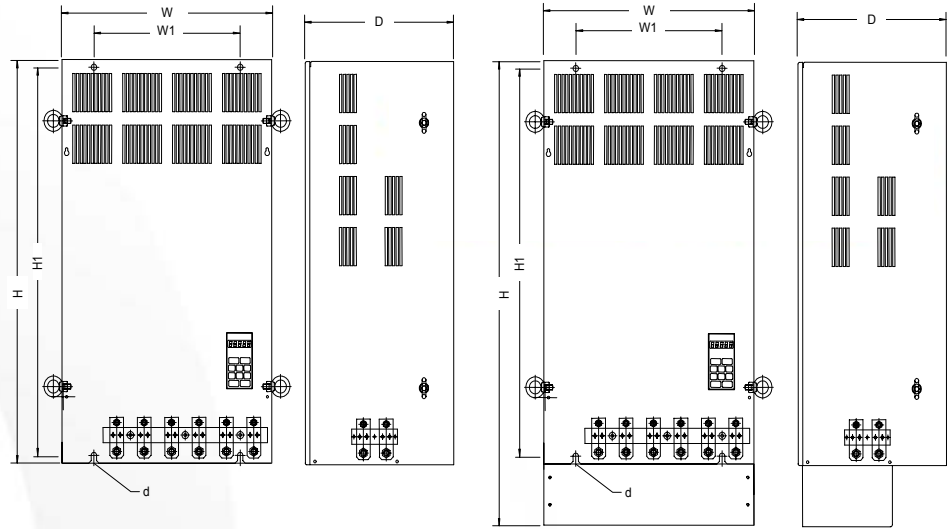

(c) 440V : 300HP, 400HP

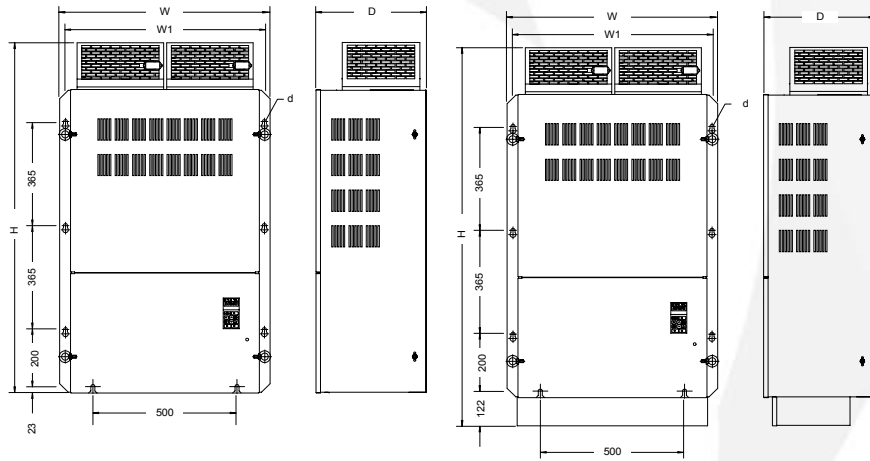

(Open Chassis Type - IP00)

(Wall-mounted Type - NEMA1)

(Open Chassis Type - IP00) (Wall-mounted Type - NEMA1)

e) Connection Diagram

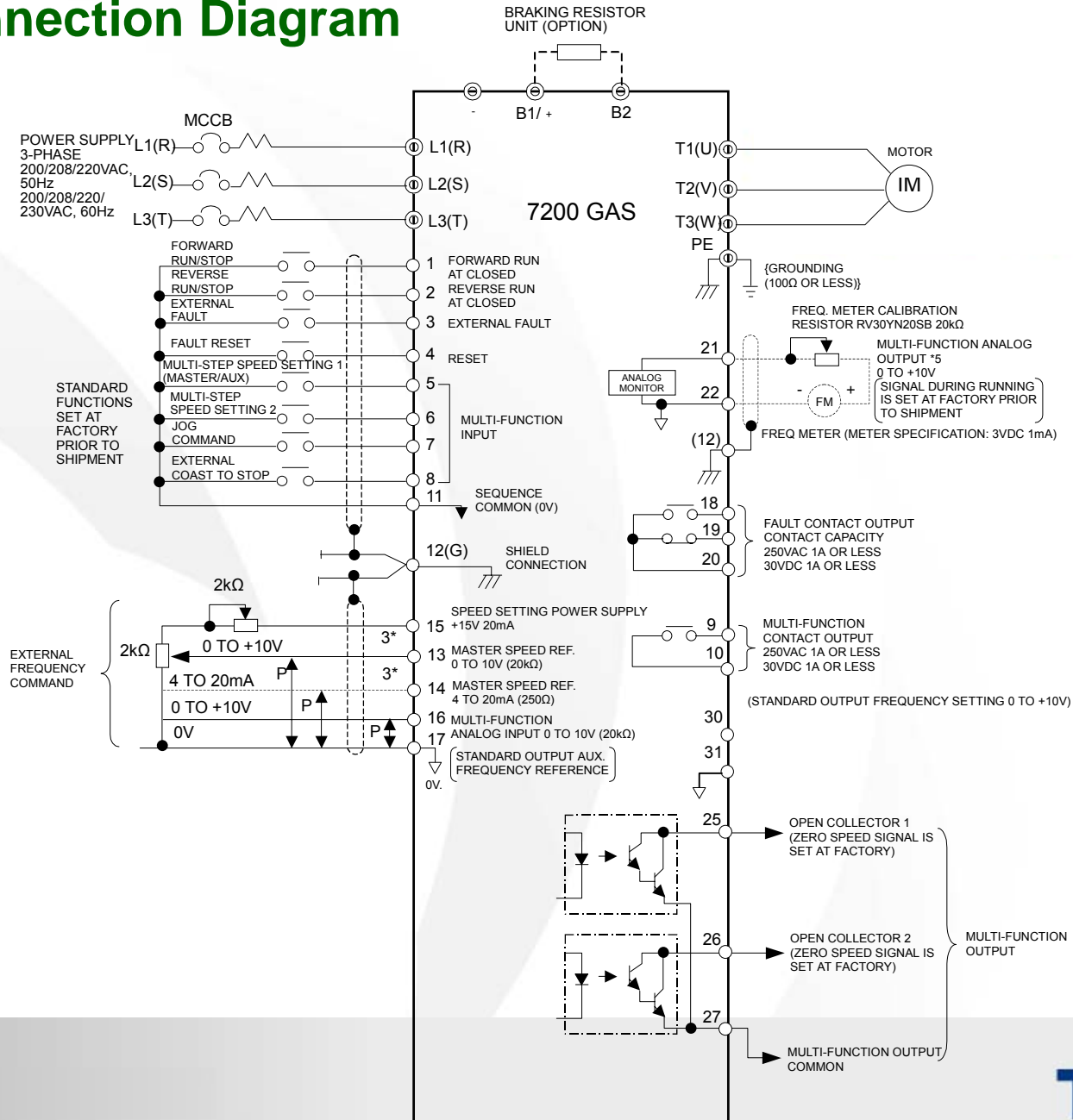

3. Target Market

a) 7200GA replacement

- Reduced Cost and dimension.
- Included all the 7200GA's parameters, and with the same parameter No.
- The same operation as 7200GA.

b) Competition

- Function upgrade (V/F, V/F+PG, PID & Auto Energy Saving, Sensorless Vector)
- Multi-Language LCD keypad.
- CE, UL

4. Sales Point

No.	Features	Descriptions
1	4 in 1 function	<p>The 7200GS standard with four selectable control modes :</p> <ul style="list-style-type: none"> ① GP : V/F Control mode (General purpose V/F control mode) ② SL : Sensorless vector control (with motor parameters auto tuning function) ③ PID : PID with Auto Energy Saving control mode. ④ PG : V/F+ PG closed loop control mode. <p>The four type control modes can be selected by the 1st and 2nd digit of parameter Sn-13 :</p> <p>◆ Control Mode</p> <pre> graph LR GP[GP : V/F Control] --> Sn13[Sn-13] SL[SL : Sensorless Control] --> Sn13 PID[PID : PID Control] --> Sn13 PG[PG : V/F+PG Feedback] --> Sn13 Sn13 --> Out[Output Control Mode (Un-11)] </pre> <p>XX00: GP XX01: SL XX10: PID XX11: PG</p>

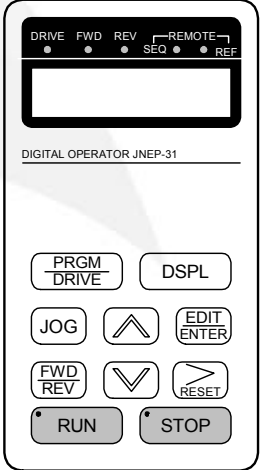
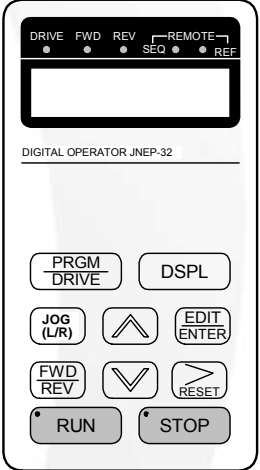
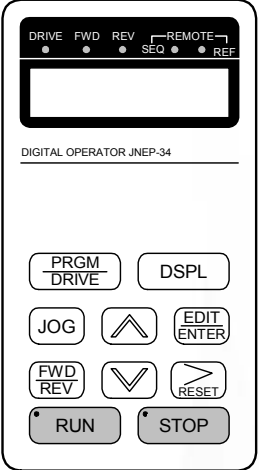
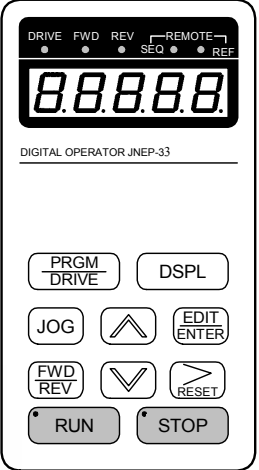
No.	Features	Descriptions
3	LCD OP	<ul style="list-style-type: none"> ● Use Graphic LCD. Dual language (Chinese & English) ● Big size LED operator (optional) ● Key function similar to as existent TECO inverter. ● Digital operator extension cable (1m, 2m, 3m, 5m, 10m) <hr/> <div style="display: flex; justify-content: space-around;"> <div style="text-align: center;"> <p>■ 7200MA LCD OP JNEP-31</p>  </div> <div style="text-align: center;"> <p>■ 7300PA LCD OP JNEP-32</p>  </div> <div style="text-align: center;"> <p>■ 7200GS LCD OP JNEP-34</p>  </div> <div style="text-align: center;"> <p>■ 7200GS LED OP JNEP-33</p>  </div> </div> <p>*• JNEP-12: GA LED OP</p> <ul style="list-style-type: none"> • JNEP-31: MA LCD OP (JNEP-31V) • JNEP-32: PA LCD OP • JNEP-33: big LED OP (MA, PA, GS,...) • JNEP-34: GS LCD OP • JNEP-35: CX LED OP • JNEP-36: MA LCD OP (Saf.)

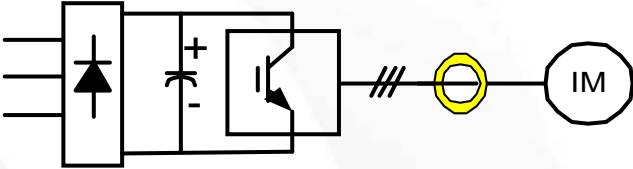
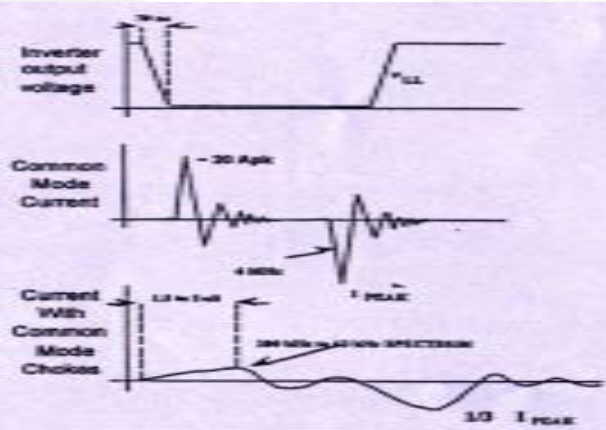
No.	Features	Descriptions
4	C.M. noise reduction	<p>● C.M. ferrite core (output zero phase filter) is built-in as standard to reduce Common Mode noise.</p>   <p>$t_r = 0.05 \mu s \sim 0.2 \mu s$</p> <p>Without core – noise frequency $f_n = 1.6 \sim 6.36 \text{ MHz}$ $di/dt = 200 \text{ A/us}$</p> <p>With core -- noise frequency $f_n = 63.6 \sim 212 \text{ KHz}$ $di/dt = 1 \text{ A/us}$</p>



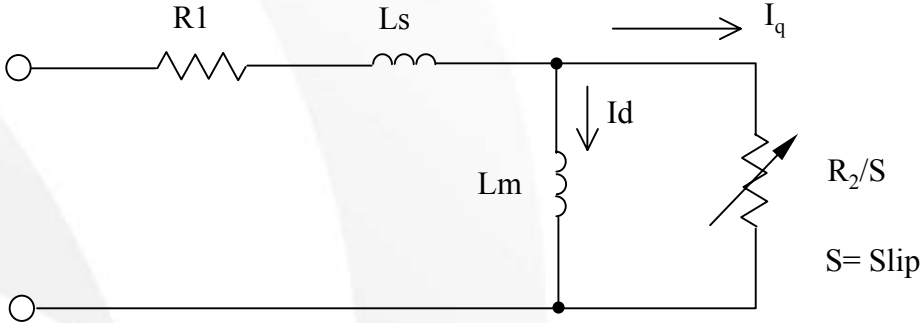

No.	Features	Descriptions																															
5	Option Card	<ul style="list-style-type: none"> 7200GS with various Option cards. <table border="1"> <thead> <tr> <th>Type</th> <th>Name</th> <th>Descriptions</th> </tr> </thead> <tbody> <tr> <td rowspan="3">RS-485 Communication</td> <td>High Speed MODBUS SI-M</td> <td> <ul style="list-style-type: none"> MODBUS RTU Protocol Interface : RS-232, RS-422, RS-485 </td> </tr> <tr> <td>Low Cost MODBUS GS-M</td> <td> <ul style="list-style-type: none"> MODBUS RTU Protocol Through RS-232 port </td> </tr> <tr> <td>Low Cost PROFIBUS GS-P</td> <td> <ul style="list-style-type: none"> PROFIBUS Protocol Through RS-232 port </td> </tr> <tr> <td>Speed Feedback</td> <td>PG speed card FB-C</td> <td> <ul style="list-style-type: none"> A phase PG freq. range : 65,535 HZ </td> </tr> <tr> <td>Pulse Output</td> <td>Digital pulse monitor card PM-C</td> <td> <ul style="list-style-type: none"> x1F, x6F, x10F, x12F, x36F </td> </tr> <tr> <td>Analog Output</td> <td>Analog monitor card AO-12</td> <td> <ul style="list-style-type: none"> 2 Channel </td> </tr> <tr> <td>Digital Input</td> <td>Digital Reference Card DI-08</td> <td> <ul style="list-style-type: none"> BCD 2 digits / Binary 8 bits </td> </tr> <tr> <td>Analog Input</td> <td>Analog Reference Card AI-14B</td> <td> <ul style="list-style-type: none"> Input : -10V~+10V, 3 Channel </td> </tr> <tr> <td>V/I</td> <td>V/I Conversion Card V/I</td> <td> <ul style="list-style-type: none"> 0~10V / 4 ~ 20mA </td> </tr> <tr> <td>Digital Output</td> <td>Digital Output Card DO-08</td> <td> <ul style="list-style-type: none"> photo coupler x 6 channel Relay x 2 channel </td> </tr> </tbody> </table>	Type	Name	Descriptions	RS-485 Communication	High Speed MODBUS SI-M	<ul style="list-style-type: none"> MODBUS RTU Protocol Interface : RS-232, RS-422, RS-485 	Low Cost MODBUS GS-M	<ul style="list-style-type: none"> MODBUS RTU Protocol Through RS-232 port 	Low Cost PROFIBUS GS-P	<ul style="list-style-type: none"> PROFIBUS Protocol Through RS-232 port 	Speed Feedback	PG speed card FB-C	<ul style="list-style-type: none"> A phase PG freq. range : 65,535 HZ 	Pulse Output	Digital pulse monitor card PM-C	<ul style="list-style-type: none"> x1F, x6F, x10F, x12F, x36F 	Analog Output	Analog monitor card AO-12	<ul style="list-style-type: none"> 2 Channel 	Digital Input	Digital Reference Card DI-08	<ul style="list-style-type: none"> BCD 2 digits / Binary 8 bits 	Analog Input	Analog Reference Card AI-14B	<ul style="list-style-type: none"> Input : -10V~+10V, 3 Channel 	V/I	V/I Conversion Card V/I	<ul style="list-style-type: none"> 0~10V / 4 ~ 20mA 	Digital Output	Digital Output Card DO-08	<ul style="list-style-type: none"> photo coupler x 6 channel Relay x 2 channel
Type	Name	Descriptions																															
RS-485 Communication	High Speed MODBUS SI-M	<ul style="list-style-type: none"> MODBUS RTU Protocol Interface : RS-232, RS-422, RS-485 																															
	Low Cost MODBUS GS-M	<ul style="list-style-type: none"> MODBUS RTU Protocol Through RS-232 port 																															
	Low Cost PROFIBUS GS-P	<ul style="list-style-type: none"> PROFIBUS Protocol Through RS-232 port 																															
Speed Feedback	PG speed card FB-C	<ul style="list-style-type: none"> A phase PG freq. range : 65,535 HZ 																															
Pulse Output	Digital pulse monitor card PM-C	<ul style="list-style-type: none"> x1F, x6F, x10F, x12F, x36F 																															
Analog Output	Analog monitor card AO-12	<ul style="list-style-type: none"> 2 Channel 																															
Digital Input	Digital Reference Card DI-08	<ul style="list-style-type: none"> BCD 2 digits / Binary 8 bits 																															
Analog Input	Analog Reference Card AI-14B	<ul style="list-style-type: none"> Input : -10V~+10V, 3 Channel 																															
V/I	V/I Conversion Card V/I	<ul style="list-style-type: none"> 0~10V / 4 ~ 20mA 																															
Digital Output	Digital Output Card DO-08	<ul style="list-style-type: none"> photo coupler x 6 channel Relay x 2 channel 																															
		<p>(Upper)</p> <p>Control Board</p> <p>Digital operator</p> <p>2CN</p> <p>3CN</p> <p>1 C</p> <p>Ground (Green)</p> <p>Control Terminal</p> <p>(Bottom)</p> <p>Main Circuit Terminal</p>																															

N o.	Features	Descriptions																																																						
5	Option Cards (Continue)	<p data-bbox="573 265 1169 301">● Option card and Valid Access Levels</p> <p data-bbox="1287 251 1420 282">O : Valid</p> <p data-bbox="1292 315 1448 347">X : Invalid</p> <table border="1" data-bbox="550 376 1374 1105"> <thead> <tr> <th data-bbox="555 381 801 458">Option Card</th> <th data-bbox="801 381 944 458">VF</th> <th data-bbox="944 381 1087 458">SL</th> <th data-bbox="1087 381 1229 458">PID</th> <th data-bbox="1229 381 1374 458">PG</th> </tr> </thead> <tbody> <tr> <td data-bbox="555 458 801 525">SI-M</td> <td data-bbox="801 458 944 525">O</td> <td data-bbox="944 458 1087 525">O</td> <td data-bbox="1087 458 1229 525">X</td> <td data-bbox="1229 458 1374 525">X</td> </tr> <tr> <td data-bbox="555 525 801 592">GS-M</td> <td data-bbox="801 525 944 592">O</td> <td data-bbox="944 525 1087 592">O</td> <td data-bbox="1087 525 1229 592">O</td> <td data-bbox="1229 525 1374 592">O</td> </tr> <tr> <td data-bbox="555 592 801 659">GS-P</td> <td data-bbox="801 592 944 659">O</td> <td data-bbox="944 592 1087 659">O</td> <td data-bbox="1087 592 1229 659">O</td> <td data-bbox="1229 592 1374 659">O</td> </tr> <tr> <td data-bbox="555 659 801 726">FB-C</td> <td data-bbox="801 659 944 726">X</td> <td data-bbox="944 659 1087 726">X</td> <td data-bbox="1087 659 1229 726">X</td> <td data-bbox="1229 659 1374 726">O</td> </tr> <tr> <td data-bbox="555 726 801 793">PM-C</td> <td data-bbox="801 726 944 793">O</td> <td data-bbox="944 726 1087 793">X</td> <td data-bbox="1087 726 1229 793">O</td> <td data-bbox="1229 726 1374 793">X</td> </tr> <tr> <td data-bbox="555 793 801 861">AO-12</td> <td data-bbox="801 793 944 861">O</td> <td data-bbox="944 793 1087 861">O</td> <td data-bbox="1087 793 1229 861">O</td> <td data-bbox="1229 793 1374 861">X</td> </tr> <tr> <td data-bbox="555 861 801 928">DI-08</td> <td data-bbox="801 861 944 928">O</td> <td data-bbox="944 861 1087 928">O</td> <td data-bbox="1087 861 1229 928">O</td> <td data-bbox="1229 861 1374 928">O</td> </tr> <tr> <td data-bbox="555 928 801 995">AI-14B</td> <td data-bbox="801 928 944 995">O</td> <td data-bbox="944 928 1087 995">O</td> <td data-bbox="1087 928 1229 995">O</td> <td data-bbox="1229 928 1374 995">O</td> </tr> <tr> <td data-bbox="555 995 801 1062">DO-08</td> <td data-bbox="801 995 944 1062">O</td> <td data-bbox="944 995 1087 1062">O</td> <td data-bbox="1087 995 1229 1062">O</td> <td data-bbox="1229 995 1374 1062">X</td> </tr> </tbody> </table>					Option Card	VF	SL	PID	PG	SI-M	O	O	X	X	GS-M	O	O	O	O	GS-P	O	O	O	O	FB-C	X	X	X	O	PM-C	O	X	O	X	AO-12	O	O	O	X	DI-08	O	O	O	O	AI-14B	O	O	O	O	DO-08	O	O	O	X
Option Card	VF	SL	PID	PG																																																				
SI-M	O	O	X	X																																																				
GS-M	O	O	O	O																																																				
GS-P	O	O	O	O																																																				
FB-C	X	X	X	O																																																				
PM-C	O	X	O	X																																																				
AO-12	O	O	O	X																																																				
DI-08	O	O	O	O																																																				
AI-14B	O	O	O	O																																																				
DO-08	O	O	O	X																																																				

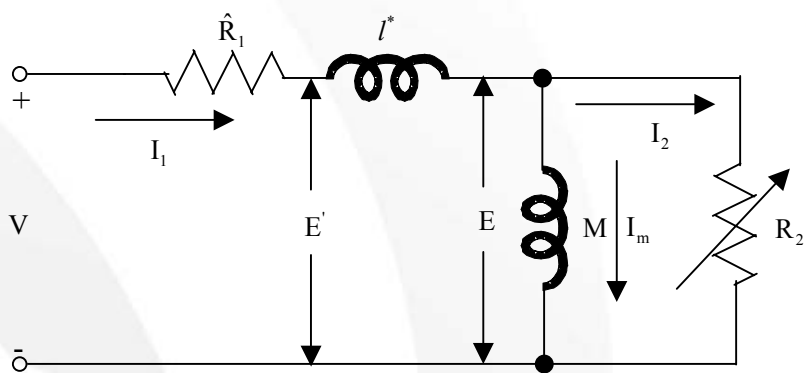
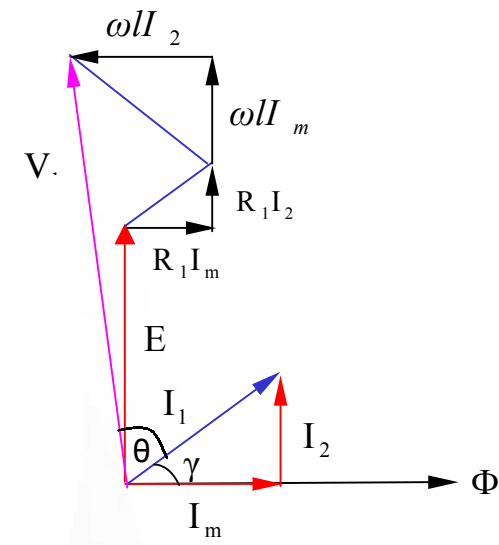
No.	Features	Descriptions																														
6	Multi-Function analog output	<ul style="list-style-type: none"> ● Multi-Function analog output (terminal ⑳—㉑), output signal can be selected according to Sn-05 4th digit and Sn-09 2nd digit set value. ● Output signal level is set by bn-11 <table border="1" data-bbox="407 394 1778 915"> <thead> <tr> <th data-bbox="407 394 592 501">Sn-05 4th digit</th> <th data-bbox="592 394 782 501">Sn-09 2nd digit</th> <th data-bbox="782 394 1030 501">GP mode (V/F)</th> <th data-bbox="1030 394 1281 501">SL mode (Sensorless)</th> <th data-bbox="1281 394 1530 501">PID mode</th> <th data-bbox="1530 394 1778 501">PG mode (V/F+PG)</th> </tr> </thead> <tbody> <tr> <td data-bbox="407 501 592 605">0</td> <td data-bbox="592 501 782 605">0</td> <td data-bbox="782 501 1030 605">Output Frequency</td> <td data-bbox="1030 501 1281 605">Output Frequency</td> <td data-bbox="1281 501 1530 605">Output Frequency</td> <td data-bbox="1530 501 1778 605">Not used</td> </tr> <tr> <td data-bbox="407 605 592 709">1</td> <td data-bbox="592 605 782 709">0</td> <td data-bbox="782 605 1030 709">Output Current</td> <td data-bbox="1030 605 1281 709">Output Current</td> <td data-bbox="1281 605 1530 709">Output Current</td> <td data-bbox="1530 605 1778 709">Not used</td> </tr> <tr> <td data-bbox="407 709 592 813">0</td> <td data-bbox="592 709 782 813">1</td> <td data-bbox="782 709 1030 813">Output Voltage</td> <td data-bbox="1030 709 1281 813">Output Voltage</td> <td data-bbox="1281 709 1530 813">Output Voltage</td> <td data-bbox="1530 709 1778 813">Not used</td> </tr> <tr> <td data-bbox="407 813 592 915">1</td> <td data-bbox="592 813 782 915">1</td> <td data-bbox="782 813 1030 915">Output Power</td> <td data-bbox="1030 813 1281 915">Output Torque</td> <td data-bbox="1281 813 1530 915">Output Power</td> <td data-bbox="1530 813 1778 915">Not used</td> </tr> </tbody> </table> <ul style="list-style-type: none"> ● AO-12 optional card can be selected to provided additional two channels of multi-function analog output. 	Sn-05 4th digit	Sn-09 2nd digit	GP mode (V/F)	SL mode (Sensorless)	PID mode	PG mode (V/F+PG)	0	0	Output Frequency	Output Frequency	Output Frequency	Not used	1	0	Output Current	Output Current	Output Current	Not used	0	1	Output Voltage	Output Voltage	Output Voltage	Not used	1	1	Output Power	Output Torque	Output Power	Not used
Sn-05 4th digit	Sn-09 2nd digit	GP mode (V/F)	SL mode (Sensorless)	PID mode	PG mode (V/F+PG)																											
0	0	Output Frequency	Output Frequency	Output Frequency	Not used																											
1	0	Output Current	Output Current	Output Current	Not used																											
0	1	Output Voltage	Output Voltage	Output Voltage	Not used																											
1	1	Output Power	Output Torque	Output Power	Not used																											

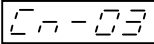
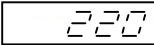
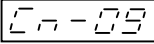
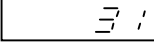
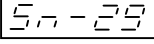
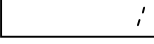
No.	Features	Descriptions
7	Sensor-less Vector	<ul style="list-style-type: none"> ● Auto-tuning : used to identify and store the important motor parameters in the first time sensorless vector operation after installation. ● The Induction Motor Y-equivalent model. <div style="text-align: center;">  <p style="text-align: right; margin-right: 50px;">R_2/S $S = \text{Slip}$</p> </div> <ul style="list-style-type: none"> • Bn-08 : Slip • Cn-09 : Motor Rated Current • Cn-31 : Motor Terminal Resistance (R1) • Cn-32 : Motor Leakage Inductance (LS) • Cn-33 : Torque Limiter • Cn-34 : Motor No Load Current • Sn-29 : Motor Parameters Auto-tuning Selection.

No.	Features	Descriptions
7	Sensor-less Vector (continue)	<p>● Sensor-less Vector Control</p> <p style="text-align: center;">Sensorless CONTROL</p>  <div style="display: flex; justify-content: space-between; align-items: flex-start;"> <div data-bbox="1237 299 1656 399"> $V_{1d} = R_1 I_m - \omega L_2 I_2$ $V_{1q} = E + R_1 I_2 + \omega L_m I_m$ </div> <div data-bbox="1237 428 1732 971">  </div> </div> <p style="margin-top: 20px;"> V : V/F Control V_1 : Voltage Vector $\Rightarrow V_1 \quad I_1 \quad I_2 \quad \text{Torque}$ I_1 : Current Vector $\Rightarrow I_1 \quad I_2 \quad \text{Torque}$ </p>

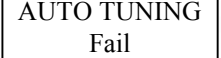
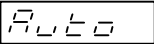
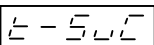
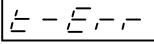
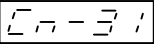
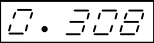
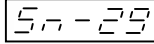
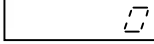
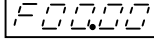
No.	Features	Descriptions		
7	Sensor-less Vector (continue)	<p>● Auto tuning The Operation Sequence and Display of Motor Parameter Autotuning.</p>		
		Operation Sequence	LCD Display	LCD Display
		Key in motor rated voltage data to Cn-03 (example: 220V)	Cn-03=220V Max. Voltage	 
		Key in motor rated current to Cn-09 (example: 31A)	Cn-09=031A Motor Rated I	 
		Enable the Autotuning function by setting Sn-29=1	Sn-29=1 AUTO TUNE SEL	 
		Switch to DRIVE operation mode by pressing the  key, then run run the inverter by pressing the  key Autotuning operation completed. (success) Autotuning operation fail.	  	  
		To read the motor terminal resistance. (example:0.308)	Cn-31=0.308 Motor Line R	 
		Switch to normal operation by setting Sn-29=0 Selected DRIVE mode	Sn-29=0 AUTO TUNE SEL Freq. Cmd. 00.00HzTECO	  

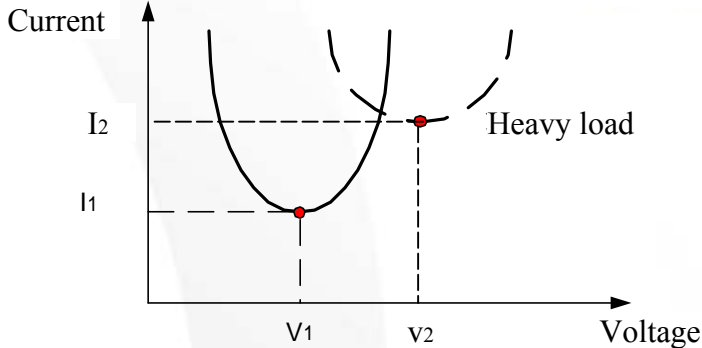
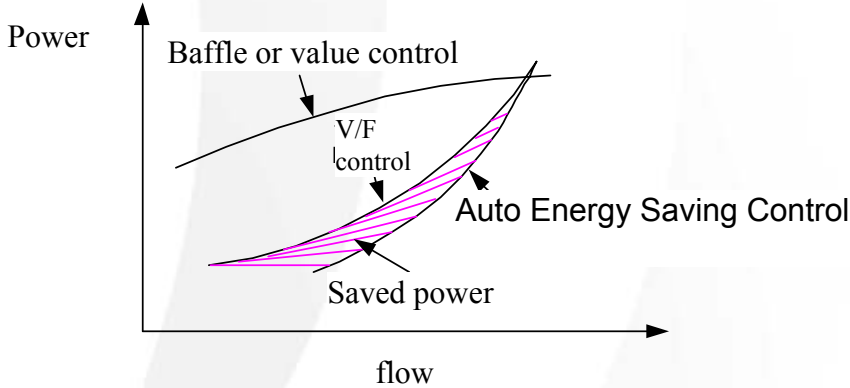
No.	Features	Descriptions
8	Auto Energy Saving (AES)	<p>■ When the PID control mode is selected (Sn-13=10), the AES (Auto Energy Saving) function adjust an optimum output voltage to minimize the inverter output current automatically according to the load.</p>  <p>■ For fans, pumps and HVAC application, the auto energy saving mode will consume less power.</p> 

No.	Features	Descriptions
9	Other	<ul style="list-style-type: none"> ❑ Monitoring parameter <ul style="list-style-type: none"> • Un-11: Control mode (V/F, SL, PID, PG) • Un-12: Output monitor <ul style="list-style-type: none"> -- Output torque (SL mode) -- Output P.F. (PID mode) --Speed feedback (PG mode) • Un-13: Speed Control Compensation (PG mode) ❑ Motor parameter Auto turning <ul style="list-style-type: none"> • Sn-29=0: Auto turning invalid =1: Auto turning valid ❑ Multi-Language LCD <ul style="list-style-type: none"> • Sn-23=0: English =1: Chinese ❑ 7200GA's functions <ul style="list-style-type: none"> • e.g. Auto torque boost Slip Compensation Speed Search Up/ Down Control etc.

5. Product Comparison

a) The basic differences of 7200GS and 7200GA in H/W

NO.	Items	7200GS	7200GA
1	Capacity range	220V : 25~100 HP 440V : 25~400 HP	220V : (1~10) 15~100 HP 440V : (1~10) 15~400 HP
2	Control board	Code NO : 4H300D4820002 (16 bit cpu + ASIC + CPLD)	Code NO : 3H300D1490008 (16 bit cpu + ASIC)
3	Power board	Same as 7300PA	GA need power board
4	Power device	IGBT : Latest generation (4 th and 5 th Gen.) Rectifier : DM, DM+Thyristor	IGBT : 3rd generation Rectifier : DM
5	Keypad	Standard : LCD JNEP-34 [Chinese display: 2 rows x 8 characters English display: 2 rows x 20 characters] Option : LED JNEP-33 (5 digits big size) Extension Cable : 1m, 2m, 3m, 5m, 10m (phone Jack)	Standard : LED JNEP-12 (5 digits small size) Extension Cable : 1m, 2m, 3m, 5m (DB9 connector)
6	I/O	DI X 8 AI X 3 AO X 1 DO X 4 (Relay X 2, photo couple X 2)	Same
7	EPR0M(memory)	27C 1024 X 2 (1M bytes X 2)	27C 256 X 2 (256K bytes X 2)

(Continue)

NO.	Items	7200GS	7200GA
8	RS-485 Communication	SI-M, MODBUS (through 2 CN)	SC-M, SE-M MODBUS (through 2 CN)
		GS-M, MODBUS (through RS-232 port, 1 CN phone Jack)	SC-M, MODBUS(through RS-232 port, 1 CN DB9 connector)
		GS-P, PROFIBUS(through RS-232 port, 1 CN phone Jack)	SC-P, PROFIBUS(through RS-232 port, 1 CN, DB9 connector)
9	Carrier Frequency	220V : 1~30 HP (15 KHz) 40~100 HP (10 KHz)(60-100HP factory set 3KHz) 440V : 1~20 HP (15 KHz) 25~75 HP (10 KHz) 100~215 HP (5~10 KHz), (100-215HP factory set 3KHz) 250~400 HP (2 KHz)	220V : 1~30 HP (15 KHz) 40~100 HP (10 KHz) 440V : 1~40 HP (15 KHz) 50~215 HP (10 KHz) 250~400 HP (2 KHz)
10	Dimensions	78% average of GA'S (for 440V 25~400HP base)	100% (for 440V 25~400HP base)

Control Board

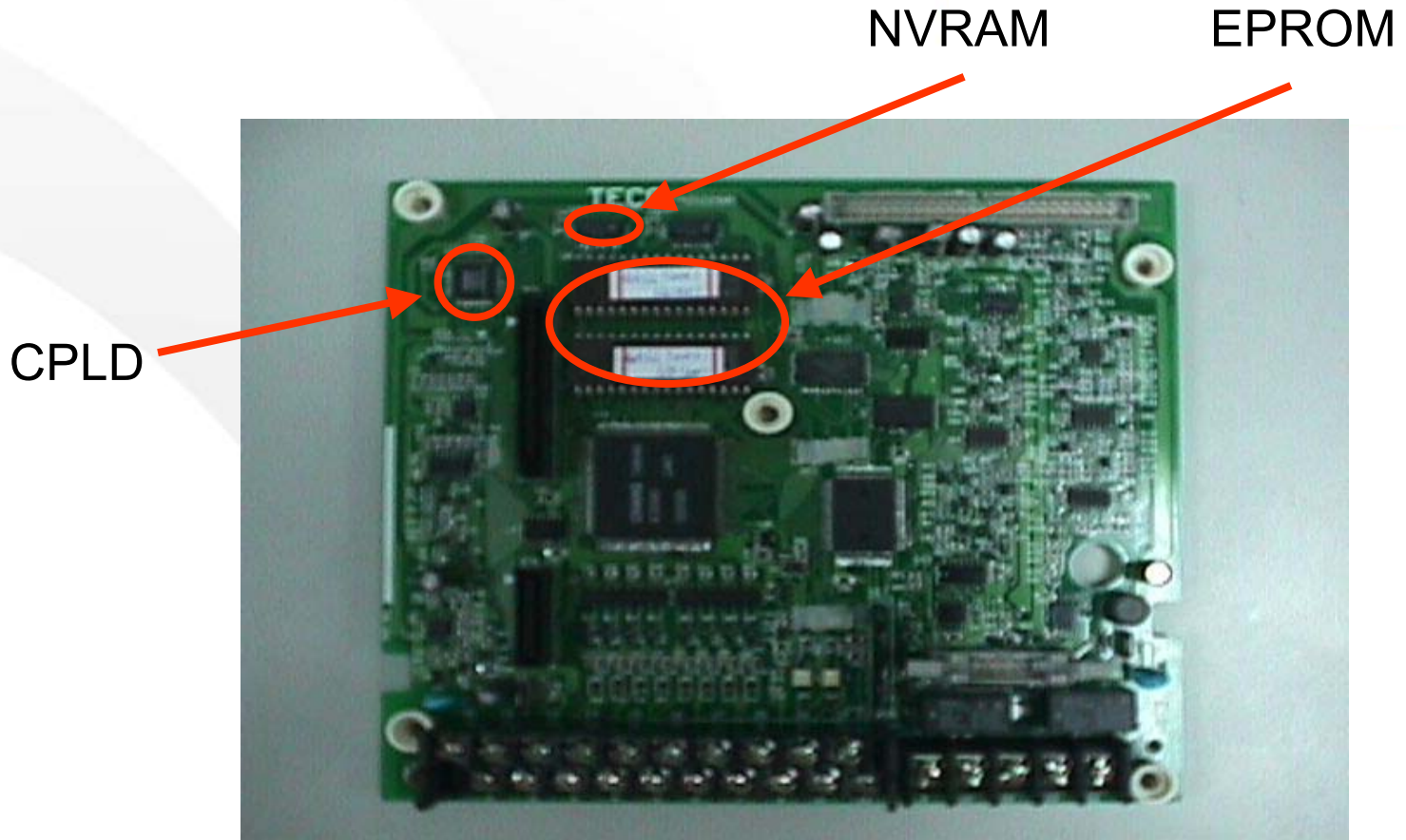

b) Comparison of 7200GS / 7200GA / 7200MA / 7300PA in function

NO.	Items	7200GS	7200GA	7200MA	7300PA	
1	Capacity range	220 V	25 ~ 100 HP	15 ~ 400 HP	1 ~ 40 HP	5 ~ 125 HP
		440 V	25 ~ 400 HP	15 ~ 400 HP	1 ~ 100 HP	5 ~ 500 HP
		575 V	--	--	(1~100 HP)(planning)	(5~500 HP)(planning)
2	Control Method	<ul style="list-style-type: none"> • V/F Control • V/F+PG Control • Sensorless vector (W/Auto turning) • PID(W/Auto Energy Saving) 	<ul style="list-style-type: none"> • V/F Control • V/F+PG (Exclusive-use ROM) • PID(Exclusive-use ROM) 	<ul style="list-style-type: none"> • V/F Control • V/F+PG(PG I/F built-in) • Sensorless vector (W/ Auto turning) • PID(W/ AES) • Dual Rating (CT, VT) 	<ul style="list-style-type: none"> • V/F Control • PID (W/ AES, sleep mode) 	
3	Application	General Industry	General Industry	General Industry, fans, pumps	fans, pumps	
4	Braking function	220V : 20HP 440V : 25HP Braking IGBT built-in	220V : 20HP 440V : 20HP Braking IGBT built-in	220V : 20HP 440V : 20HP Braking IGBT built-in	220V : 25HP 440V : 30HP Braking IGBT built-in	
5	Overload Capacity	150% for 1 min	150% for 1 min	CT mode:150%for 1min VT mode:110%for 1min	110% for 1min	
6	Speed control range	<ul style="list-style-type: none"> •V/F: 1 : 10 •Sensorless: 1 : 60 	<ul style="list-style-type: none"> •V/F: 1 : 10 	<ul style="list-style-type: none"> •V/F: 1 : 10 •Sensorless: 1 : 60 	<ul style="list-style-type: none"> •V/F: 1 : 10 	

(Continue)

NO.	Items	7200GS	7200GA	7200MA	7300PA
7	Speed accuracy	<ul style="list-style-type: none"> • V/F:±1% (W/ slip comp.) • V/F+PG:±0.03%(1024 ppr PG) •Sensorless: ±0.5% 	<ul style="list-style-type: none"> • V/F:±1% (W/ slip comp.) • V/F+PG:±0.03%(1024 ppr PG) 	<ul style="list-style-type: none"> • V/F:±1% (W/ slip comp.) •V/F+PG:±0.1%(1024 ppr PG) •Sensorless: ±0.5% 	<ul style="list-style-type: none"> • V/F:±2-3% (W/O slip comp.)
8	Speed response	<ul style="list-style-type: none"> • V/F: 1 to 2Hz •Sensorless: 5Hz 	<ul style="list-style-type: none"> • V/F: 1 to 2Hz 	<ul style="list-style-type: none"> • V/F: 1 to 2Hz •Sensorless: 5Hz 	--
9	Starting torque	<ul style="list-style-type: none"> • V/F: 150% at 3Hz •Sensorless: 150% at 1Hz 	<ul style="list-style-type: none"> •V/F: 150% at 3Hz 	<ul style="list-style-type: none"> •V/F: 150% at 3Hz •Sensorless: 150% at 1Hz 	--
10	ACL or DCL (preventive actions for harmonics)	<p>220V : 1~20 HP (ACL:external) 25~100 HP(DCL:built-in)</p> <p>440V : 1~25 HP (ACL:external) 30~250HP (DCL:built-in) 300~400HP (ACL:external)</p>	<p>220V : 1~20 HP (ACL/DCL:external) 25~100 HP (DCL:built-in)</p> <p>440V : 1~20 HP (ACL/DCL:external) 25~215HP (DCL:built-in) 250~400HP(ACL:external)</p>	<p>220V : 1~25HP (ACL:external) 30~40HP(DCL:built-in)</p> <p>440V : 1~30HP(ACL:external) 40~100HP(DCL:built-in)</p>	<p>220V : 5~20HP(ACL:external) 25~125HP(DCL:built-in)</p> <p>440V : 5~25 HP (ACL:external) 30~300HP(DCL:built-in) 350~500HP (ACL:external)</p>
11	Power supply voltage variation	+10%, -15%	+10%, -15%	+10%, -15%	+10%, -15%

(Continue)

NO.	Items		7200GS	7200GA	7200MA	7300PA
12	Under Voltage	220 V	190 VDC	190 VDC	190 VDC	190 VDC
		440 V	380 VDC	380 VDC	380 VDC	380 VDC
13	RS-485 communication	MODBUS	SI-M, GS-M	SI-M, SC-M	Built-in as standard	PA-M
		PROFIBUS	GS-P	SC-P	MA-SP	PA-P
		Others	--	--	(Device net etc.)	(Metasys N2)
14	PID card		X	X	X	PA-PID card (1-8 PID)
15	Keypad		<ul style="list-style-type: none"> • Std: LCD (JNEP-33) Chinese/English (W/O copy function) • Option: LED (JNEP-34) (W/O copy function) • Max. extension cable: 10 m 	<ul style="list-style-type: none"> • Std: LED (JNEP-12) (W/O copy function) • Max. extension cable: 5 m 	<ul style="list-style-type: none"> • Std: LCD (JNEP-31) Chinese/English (W/ copy function) • Option: LED (JNEP-34) (W/O copy function) • Max. extension cable: 10 m 	<ul style="list-style-type: none"> • Std: LCD(JNEP-32) Chinese/English (W/ copy function) • Option: LED (JNEP-34) (W/O copy function) • Max. extension cable: 10 m
16	I/O Interface	DI	8 (SINK)	8 (SINK)	8 (SINK / SOURCE)	8 (SINK / SOURCE)
		DO	Relay * 2(1C, 1A) Photo coupler * 2	Relay * 2(1C, 1A) PHC * 2	Relay * 2(1C, 1A) PHC * 1	Relay * 2(1C, 1A) PHC * 2
		AI	0-10 V * 2 4-20 mA * 1	0-10 V * 2 4-20 mA * 1	0-10V * 1, -10V~ +10V * 1 4-20 mA * 1	0-10 V * 2 4-20 mA * 1
		AO	0-10 V * 1	0-10 V * 1	0-10 V * 2	0-10 V * 1

(Continue)

NO.	Items		7200GS	7200GA	7200MA	7300PA
17	C.M. choke		220V : 30~100 HP 440V : 25~250 HP built-in as standard	X	220V : 25~40 HP 440V : 25~100 HP built-in as standard	220V : 5~125 HP 440V : 5~300 HP built-in as standard
18	Phase loss protection	Input (IPL)	X	X	O	O
		Output(OPL)	X	X	O	O
19	PID		O	O (Exclusive-use ROM)	O	O
20	PID sleep mode		X	X	X	O
21	Auto Energy Saving(AES)		O	O (Exclusive-use ROM)	O	O
22	Monitor		KW, PF, Torque	KW, PF	Hr, KW, PF, KW Hr	Hr, KW, PF, KW Hr
23	PTC thermistor I/F		X	X	X	O
24	Local/ Remote switch key		X	X	O	O
25	Inverter overload (OL2) trip run delay		O	X	O	O

c) Comparison of 7200GS / 7200GA in function

■ An

Group	Parameter No.	Name	7200GS				7200GA
			GP mode (V/F)	SL mode (Sensorless)	PID mode	PG mode (V/F+PG)	
An	An-01	Frequency Command 1	Frequency Command 1				(Same as GP mode of GS)
	An-02	Frequency Command 2	Frequency Command 2				
	An-03	Frequency Command 3	Frequency Command 3				
	An-04	Frequency Command 4	Frequency Command 4				
	An-05	Frequency Command 5	Frequency Command 5				
	An-06	Frequency Command 6	Frequency Command 6				
	An-07	Frequency Command 7	Frequency Command 7				
	An-08	Frequency Command 8	Frequency Command 8				
	An-09	Jog Freq. Command	Jog Freq. Command				

Group	Parameter No.	Name	7200GS				7200GA
			GP mode (V/F)	SL mode (Sensorless)	PID mode	PG mode (V/F+PG)	
bn	bn-01	Accel Time 1	Accel Time 1				(Same as GP mode)
	bn-02	Decel Time 1	Decel Time 1				
	bn-03	Accel Time 2	Accel Time 2				
	bn-04	Decel Time 2	Decel Time 2				
	bn-05	Analog Freq. Cmd. Gain	Analog Freq. Cmd. Gain				
	bn-06	Analog Freq. Cmd. Bias	Analog Freq. Cmd. Bias				
	bn-07	Auto Torque Boost Gain	Auto Torque Boost				(Same as GP mode)
	bn-08	Slip	Slip (%)	Slip (Hz)			(Same as GP mode)
	bn-09	Energy Saving gain	Energy Saving gain				
	bn-10	Monitor NO. after power on	Monitor NO. after power on				
	bn-11	A01 Gain	A01 Gain (0.01~2.55)			Multifunction analog output (21) items (1~13)	
	bn-12	A02 Gain	A02 Gain (0.01~2.55)			Multifunction analog output (21) Gain (0.01~2.55)	
	bn-13	PID Detection Gain			PID Detection Gain		
	bn-14	PID P Gain			PID P Gain		
	bn-15	PID I Gain			PID I Gain		
	bn-16	PID D Gain			PID D Gain		
	bn-17	PID Bias			PID Bias		

■ Cn (1)

Group	Parameter No.	Name	7200GS				7200GA
			GP mode (V/F)	SL mode (Sensorless)	PID mode	PG mode (V/F+PG)	
Cn	Cn-01	Input Volt.	Input Volt				(Same as GP mode)
	Cn-02	Max. Output Freq.	Max. Output Freq				
	Cn-03	Max. Output Volt.	Max. Output Volt.				
	Cn-04	Max. Volt. Freq	Max. Volt. Freq				
	Cn-05	Middle Output Freq	Middle. Output Freq				
	Cn-06	Volt. at middle Output Freq	Volt. at middle Output Freq (Factory set 220V:16.5V)	Volt. at middle Output Freq (Factory set 220V:11.0V)			
	Cn-07	Min. Output Freq	Min. Output Freq (Factory set:1.5Hz)	Min. Output Freq (Factory set:1.0Hz)			
	Cn-08	Volt. at min. Output Freq	Volt. at min. Output Freq (Factory set :11.0V)	Volt. at min. Output Freq (Factory set :4.3V)	Volt. at min. Output Freq (Factory set :13.0V)		
	Cn-09	Motor rated current	Motor rated current				
	Cn-10	DCDB starting Freq.	DCDB starting Freq.				
	Cn-11	DCDB current	DCDB current				
	Cn-12	DCDB Time at Stop	DCDB Time at Stop (Factory set:0.5sec)		DCDB Time at Stop (Factory set:0.0sec)		
	Cn-13	DCDB Time at Start	DCDB Time at Start				
	Cn-14	Freq. Cmd. Upper Bound	Freq. Cmd. Upper Bound				
	Cn-15	Freq. Cmd. Lower Bound	Freq. Cmd. Lower Bound				
	Cn-16	Freq. Jump 1	Freq. Jump 1				
	Cn-17	Freq. Jump 2	Freq. Jump 2				

■ Cn (2)

Group	Parameter No.	Name	7200GS				7200GA
			GP mode (V/F)	SL mode (Sensorless)	PID mode	PG mode (V/F+PG)	
Cn	Cn-18	Freq. Jump 3	Freq. Jump 3				
	Cn-19	Freq. Jump Width	Freq. Jump Width				
	Cn-20	Digital Operator Display unit	Digital Operator Display unit				
	Cn-21	Freq. Agree Detection Level	Freq. Agree Detection Level				
	Cn-22	Freq. Agree Detection Width	Freq. Agree Detection Width				
	Cn-23	fc upper Limit	fc upper Limit				
	Cn-24	fc Lower Limit	fc Lower Limit				
	Cn-25	fc Gain	fc Gain				
	Cn-26	Over torque Detection Level	Over torque Detection Level				
	Cn-27	Over torque Detection Time	Over torque Detection Time				
	Cn-28	Stall prevention level during Acel.	Stall prevention level during Acel.				
	Cn-29	Constant HP Area Stall prevention	Constant HP Area Stall prevention				
	Cn-30	Stall prevention level during running	Stall prevention level during running				
	Cn-31	Motor terminal Resistance	Motor terminal Resistance				
	Cn-32	Motor Iron loss	Motor Iron loss	Motor leakage inductance (Ls)			
Cn-33	Torque Comp. Limiter	Torque Comp. Limiter (Factory: 50V)	Torque Limiter (Factory: 150%)				
Cn-34	Motor no load current	Motor no load current					

■ Cn (3)

Group	Parameter No.	Name	7200GS				7200GA
			GP mode (V/F)	SL mode (Sensorless)	PID mode	PG mode (V/F+PG)	
Cn	Cn-35	Slip Comp. Delay time	Slip Comp. Delay time (Factory set2.0s)	Slip Comp. Delay time (Factory set0.2s)			
	Cn-36	Retry Times	Retry Times				
	Cn-37	Ride-thru Time	Ride-thru Time				
	Cn-38	Speed Search Detection Level	Speed Search Detection Level				
	Cn-39	Speed Search Time	Speed Search Time				
	Cn-40	Min. B.B. Time	Min. B.B. Time				
	Cn-41	V/F Curve in Speed Search	V/F Curve in Speed Search				
	Cn-42	Volt. Recovery Time	Volt. Recovery Time				
	Cn-43	—			PID I upper Bound	PG Constant	
	Cn-44	—			PID Filter	Motor Poles	
	Cn-45	—			Energy Saving Volt. Upper Limit (60Hz)	ASR Gain 1	
	Cn-46	—			Energy Saving Volt. Upper Limit (6Hz)	ASR -Time 1	
	Cn-47	—			Energy Saving Volt. Lower Limit (60Hz)	ASR Gain 2	
	Cn-48	—			Energy Saving Volt. Lower Limit (6Hz)	ASR -Time 2	
	Cn-49	—			Tuning operation voltage Limit	ASR Upper Bound	
	Cn-50	—			Tuning operation control cycle	ASR Lower Bound	
	Cn-51	—			Tuning operation voltage stop (100%)	Speed Deviation Detection Level	

■ Cn (4)

Group	Parameter No.	Name	7200GS				7200GA
			GP mode (V/F)	SL mode (Sensorless)	PID mode	PG mode (V/F+PG)	
Cn	Cn-52	—			Tuning operation voltage step (5%)	Over speed Detection level	
	Cn-53	Reserved					
	Cn-54	Reserved					
	Cn-55	Reserved					
	Cn-56	Reserved					
	Cn-57	Reserved					
	Cn-58	—			Energy Saving K2		
	Cn-59	—			Energy Saving K2 Reduction Ratio		
	Cn-60	—			Motor code		

■ Sn (1)

Group	Parameter No.	Name	7200GS				7200GA
			GP mode (V/F)	SL mode (Sensorless)	PID mode	PG mode (V/F+PG)	
Sn	Sn-01	INV. Capacity	INV. Capacity	INV. Capacity (add. bn-08)			
	Sn-02	V/F Curve	V/F Curve				
	Sn-03	Display of operator and Initialization	Display of operator and Initialization				
	Sn-04	Operation mode Select 1	Operation mode Select 1				
	Sn-05	Operation mode Select 2	Operation mode Select 2			Operation mode Select 2 (bit3 different)	
	Sn-06	Operation mode Select 3	Operation mode Select 3				
	Sn-07	Operation mode Select 4	Operation mode Select 4	Operation mode Select 4 (bit3 different)			
	Sn-08	Operation mode Select 5	Operation mode Select 5 (AI,PI,SI-M)		Operation mode Select 5 (AI, PI, AES)	Operation mode Select 5 (AI)	
	Sn-09	Operation mode Select 6	Operation mode Select 6 (Analog output)	Operation mode Select 6 (Slip Comp. During reg.)	Operation mode Select 6 (Analog Output)		
	Sn-10	Protective Select 1	Protective Select 1				
	Sn-11	Protective Select 2	Protective Select 2				
	Sn-12	Protective Select 3	Protective Select 3				
	Sn-13	Control mode Select	Control mode Select (GP,SL,PID,PG)				
	Sn-14	Protective Select 4	Protective Select 4				
	Sn-15	Terminal Ⓢ function	Terminal Ⓢ function		Terminal Ⓢ function (add. PID control)	Terminal Ⓢ function (add. PG ON/OFF control)	
	Sn-16	Terminal Ⓣ function	Terminal Ⓣ function		Terminal Ⓣ function (add. PID control)	Terminal Ⓣ function (add. PG ON/OFF control)	
	Sn-17	Terminal Ⓩ function	Terminal Ⓩ function		Terminal Ⓩ function (add. PID control)	Terminal Ⓩ function (add. PG ON/OFF control)	

■ Sn (2)

Group	Parameter No.	Name	7200GS				7200GA
			GP mode (V/F)	SL mode (Sensorless)	PID mode	PG mode (V/F+PG)	
Sn	Sn-18	Terminal ⑧	Terminal ⑧		Terminal ⑧ (add. PID control)	Terminal ⑧ (add. PG ON/OFF control)	
	Sn-19	Terminal ①⑥	Terminal ①⑥	Terminal ①⑥ (add. PID control)	Terminal ①⑥ (add. PG ON/OFF control)		
	Sn-20	Terminal ⑨ ⑩	Terminal ⑨ ⑩				
	Sn-21	Terminal ⑳ ~ ㉑	Terminal ⑳ ~ ㉑				
	Sn-22	Terminal ㉒ ~ ㉓	Terminal ㉒ ~ ㉓				
	Sn-23	LCD Language	LCD Language				
	Sn-24	Reserved					
	Sn-25	AI-14B Card	AI-14B				
	Sn-26	PI-08 Card	PI-08				
	Sn-27	DO-08 & PM-C Card	DO-08 & PM-C	DO-08	PM-C	FB-C function 1	
	Sn-28	AO-12 Card	AO-12			FB-C function 2	
	Sn-29	—		Auto turning			

■ Un

Group	Parameter No.	Name	7200GS				7200GA
			GP mode (V/F)	SL mode (Sensorless)	PID mode	PG mode (V/F+PG)	
Un	Un-01	Freq. Cmd.	Freq. Cmd.				
	Un-02	Output Frequency	Output Frequency				
	Un-03	Output Current	Output Current				
	Un-04	Output Voltage	Output Voltage				
	Un-05	DC Voltage	DC Voltage				
	Un-06	Output Power	Output Power				
	Un-07	Input Terminal Status	Input Terminal Status				
	Un-08	Output Terminal Status	Output Terminal Status				
	Un-09	LED Check	LED Check				
	Un-10	S/W Version	S/W Version				
	Un-11	—	Control Mode Select				
	Un-12	—		Output Torque	Output Power Factor	Speed Feedback	
	Un-13	—				Speed Control Comp.	

d) Rated Current and Carrier Frequency

- Rated current

V	HP	7200GA	7200GS	F7	G7	G5
220V	25	80A	80A	71A	80A	80A
	30	96A	96A	85A	96A	96A
	40	130A	130A	115A	130A	130A
	50	160A	160A	145A	160A	160A
	60	183A	183A	180A	183A	183A
	75	224A	224A	215A	224A	224A
	100	300A	300A	283A	300A	300A
440V	25	40A	40A	39A	42A	41A
	30	48A	48A	45A	52A	52A
	40	64A	64A	60A	65A	65A
	50	80A	80A	75A	80A	80A
	60	96A	96A	91A	97A	96A
	75	128A	128A	112A	128A	128A
	100	165A	165A	150A	165A	165A
	125	192A	192A	180A	195A	—
	150	224A	224A	216A	240A	224A
	175	270A	270A	260A	270A	—
	215	300A	300A	304A	325A	300A
	250	340A	340A	370A	370A	340A
	300	450A	450A	506A	450A	450A
400	600A	600A	675A	605A	605A	

• Carrier frequency

V	HP	7200GA	7200GS	F7	G7	G5
220V	25	15KHZ	15KHZ	15KHZ		15KHZ
	30	15KHZ	15KHZ	15KHZ		10KHZ
	40	10KHZ	10KHZ	10KHZ		10KHZ
	50	10KHZ	10KHZ	10KHZ		10KHZ
	60	10KHZ	10KHZ	10KHZ		10KHZ
	75	10KHZ	10KHZ	10KHZ		10KHZ
	100	10KHZ	10KHZ	10KHZ		10KHZ
440V	25	15KHZ	10KHZ	15KHZ		15KHZ
	30	15KHZ	10KHZ	15KHZ		15KHZ
	40	15KHZ	10KHZ	10KHZ		15KHZ
	50	10KHZ	10KHZ	10KHZ		10KHZ
	60	10KHZ	10KHZ	10KHZ		10KHZ
	75	10KHZ	10KHZ	10KHZ		10KHZ
	100	10KHZ	8KHZ(3KHZ) *	10KHZ		10KHZ
	125	10KHZ	6KHZ (3KHZ) *	10KHZ		—
	150	10KHZ	6KHZ (3KHZ) *	10KHZ		10KHZ
	175	10KHZ	5KHZ (3KHZ) *	10KHZ		—
	215	10KHZ	10KHZ (3KHZ) *	10KHZ		10KHZ
	250	2KHZ	2KHZ	10KHZ		2.5KHZ
	300	2KHZ	2KHZ	2KHZ		2.5KHZ
400	2KHZ	2KHZ	2KHZ		2.5KHZ	

* Factory setting

e) Performance

- **Items** —
 - ① T-N Curve
 - ② Current Waveform
 - ③ FORWARD / REVERSE Response
 - ④ Speed Control Accuracy (at Sensorless Vector)
 - ⑤ Impact Response

T-N Curve

7200GS T-N CURVE

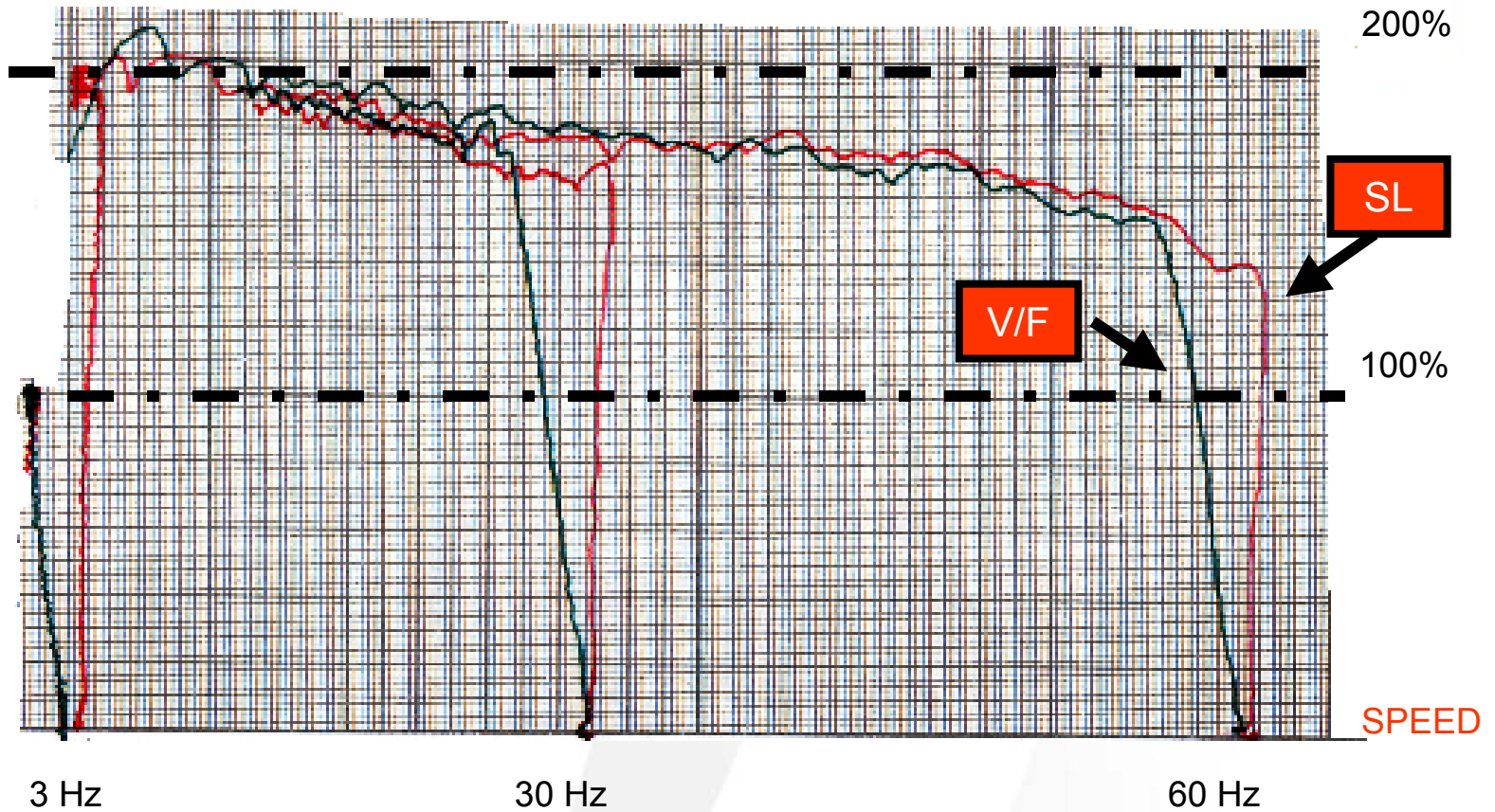

Inverter: 220V 5HP

Load Test (2hrs full load)

7200GS SENSORLESS T-N CURVE (2 Hours full load test)
(R1 ON-LINE ADPTIVE CONTROL)

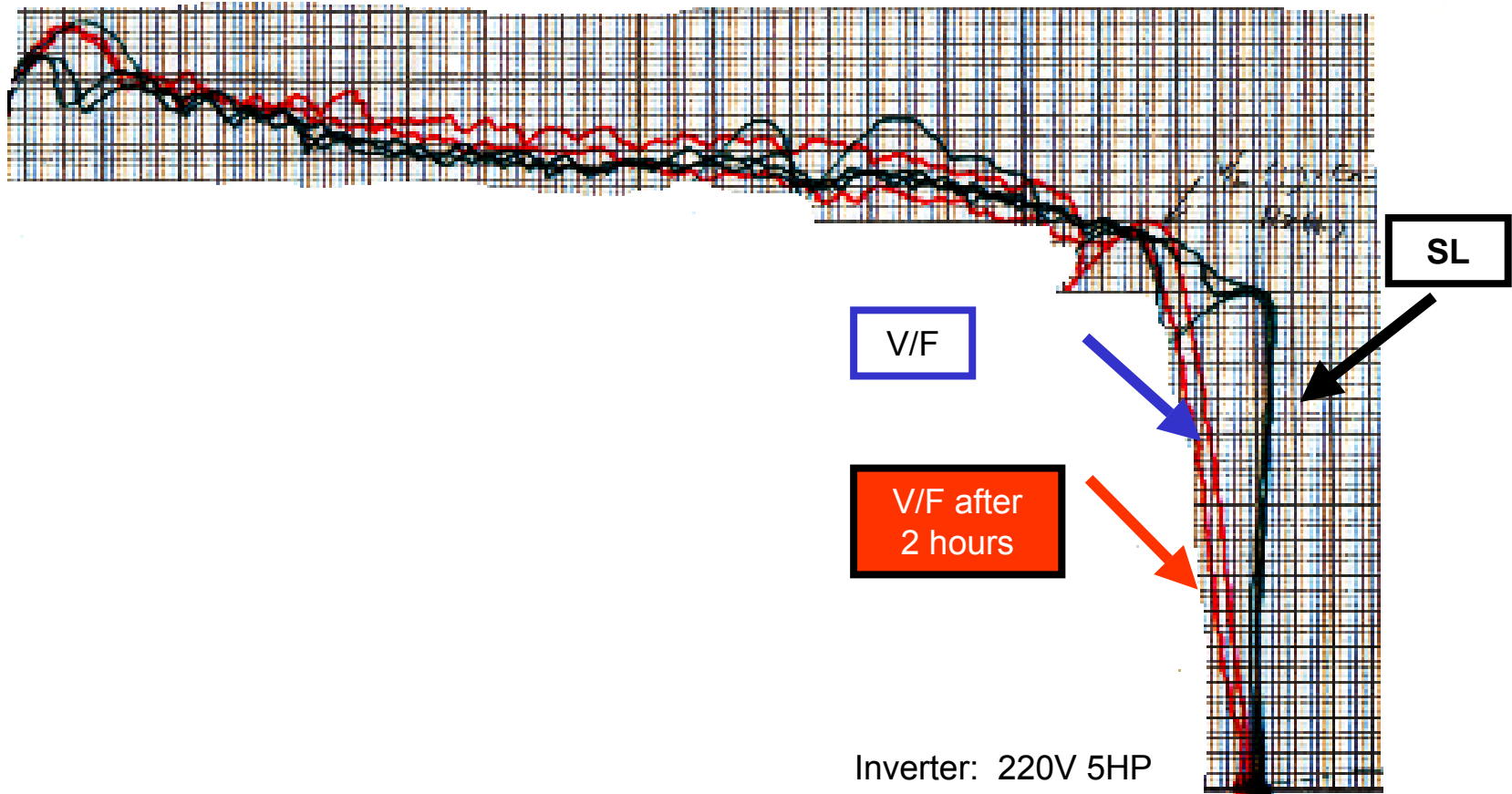

Current Wave form

(60HZ)

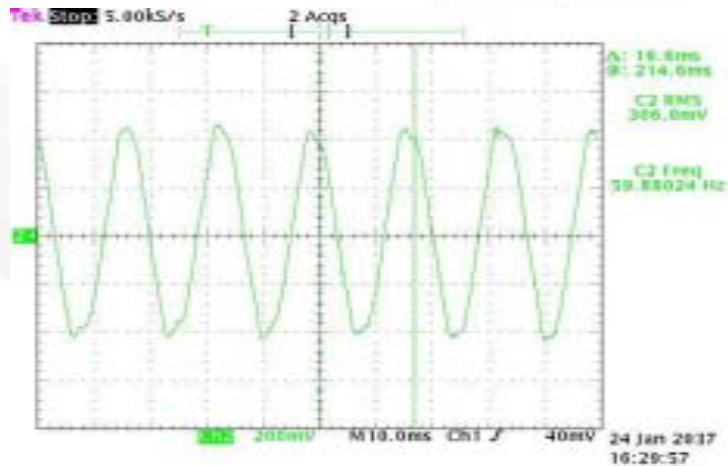

7200GS (Sensorless)

(30HZ)

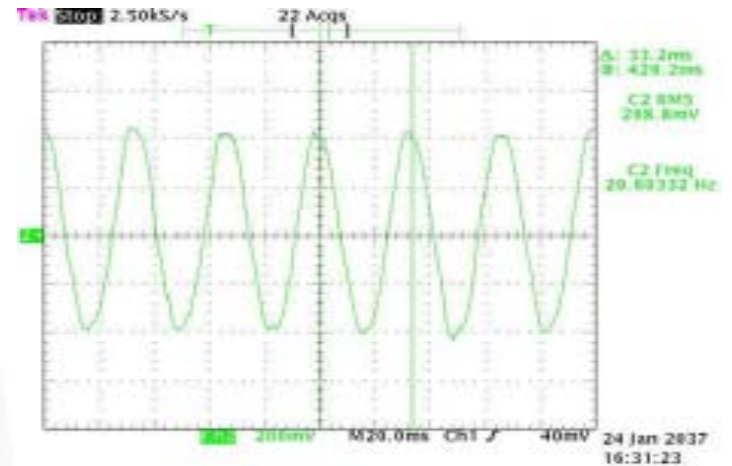

7200GS (Sensorless)

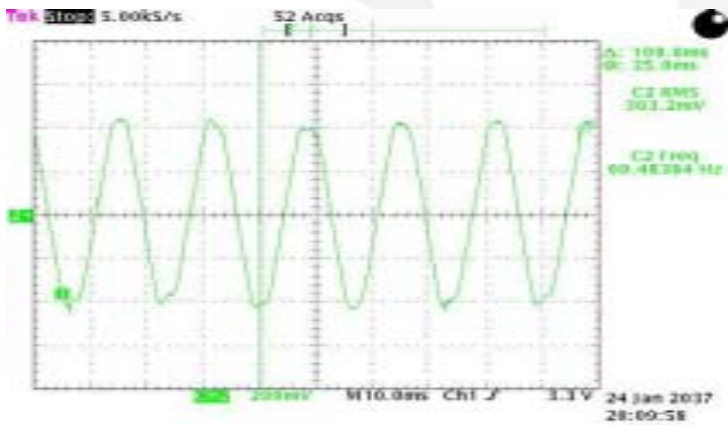

G5 (Sensorless)

Inverter: 220V 5HP

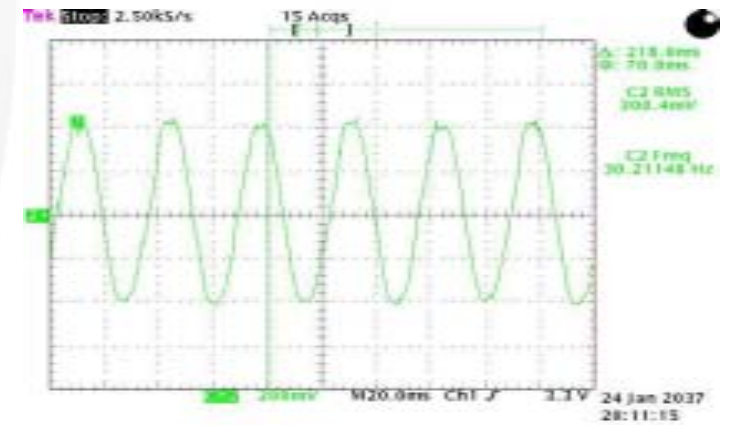

G5 (Sensorless)

FORWARD/REVERSE Response

(-60HZ 60HZ)

(60HZ -60HZ)

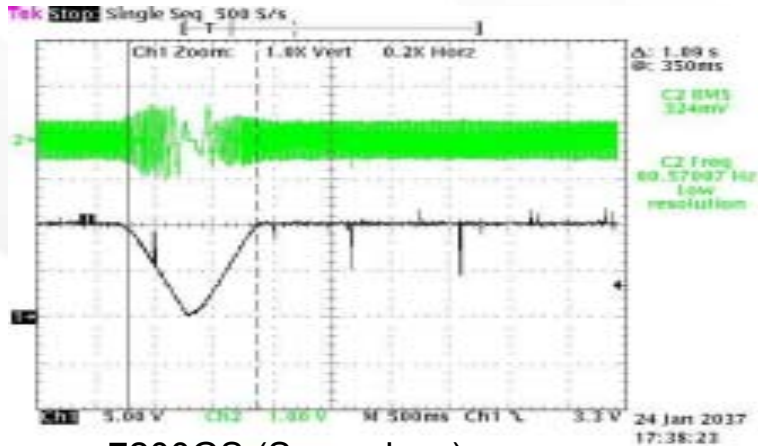

7200GS (Sensorless)

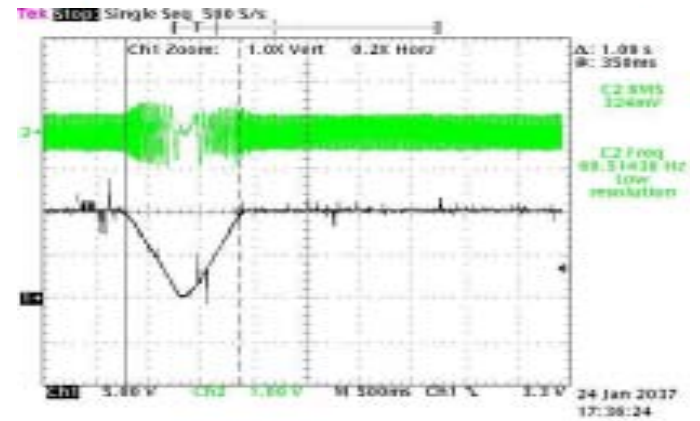

7200GS (Sensorless)

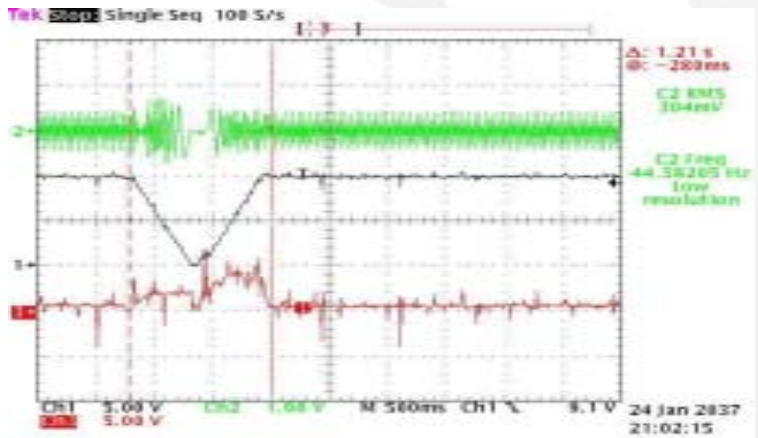

G5 (Sensorless)

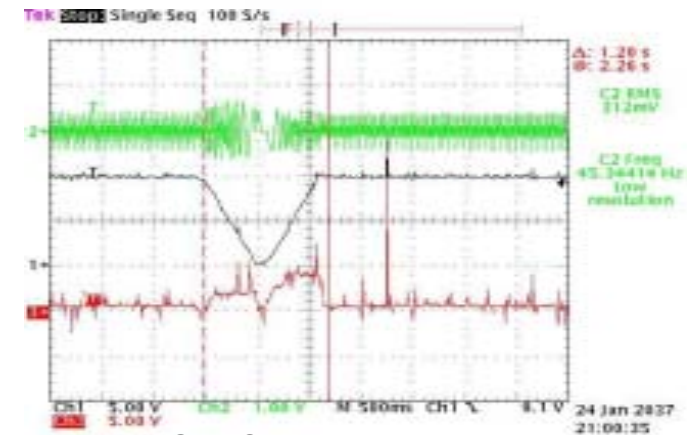

G5 (Sensorless)

Inverter: 220V 5HP

Speed Control Accuracy (Sensorless Vector)

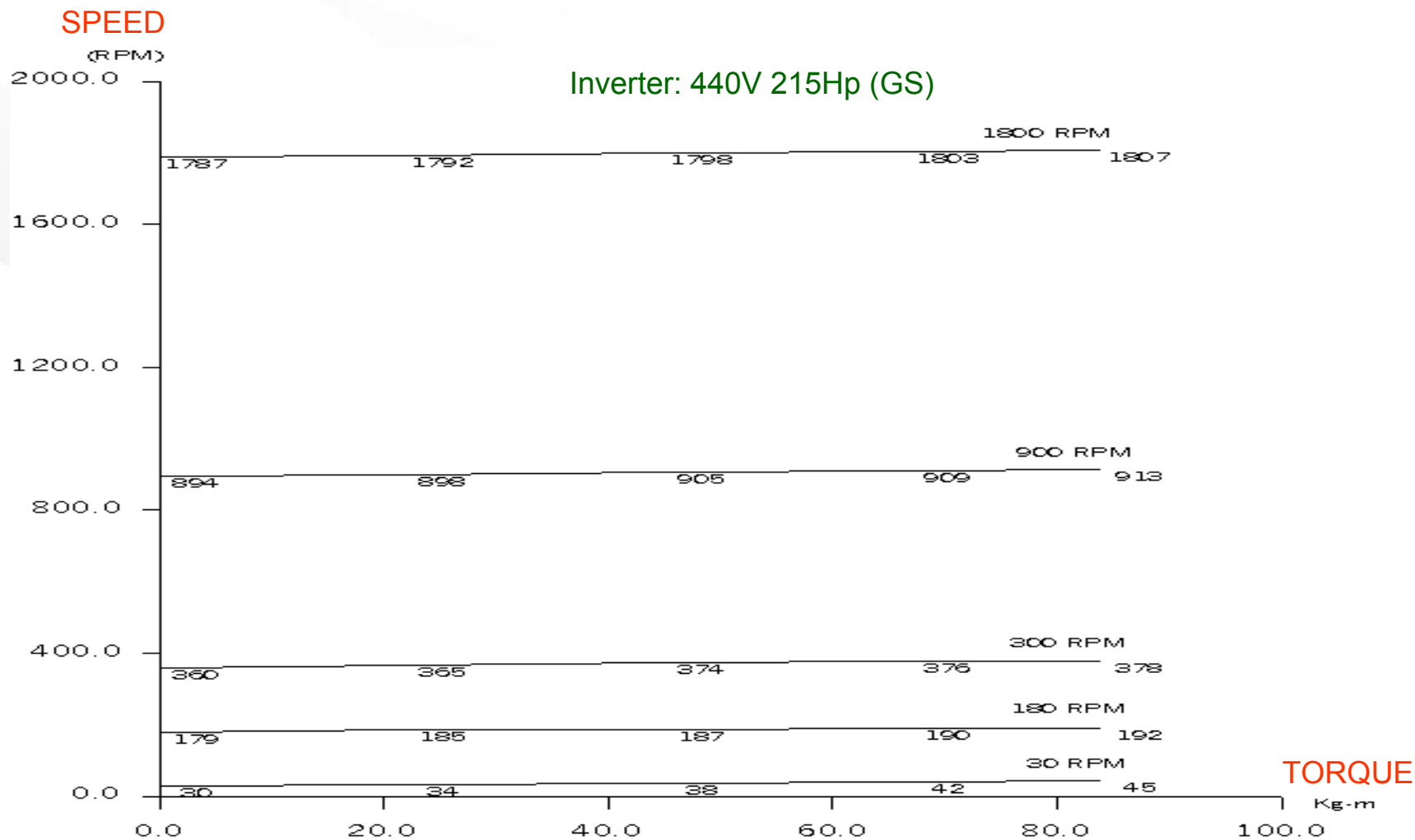

IMPACT Response (50HZ 60HZ)

Inverter: 220V 5HP

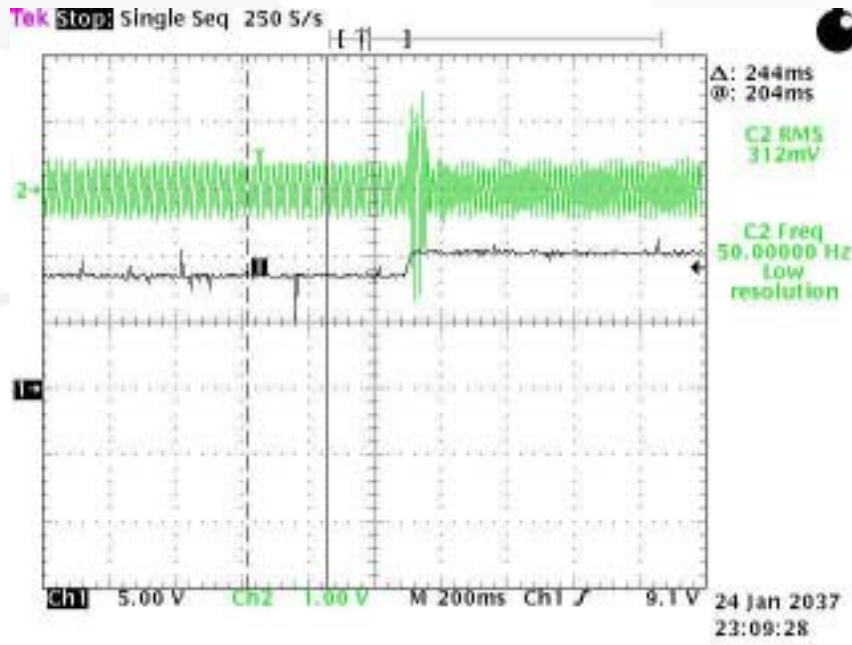

GS (Sensorless)

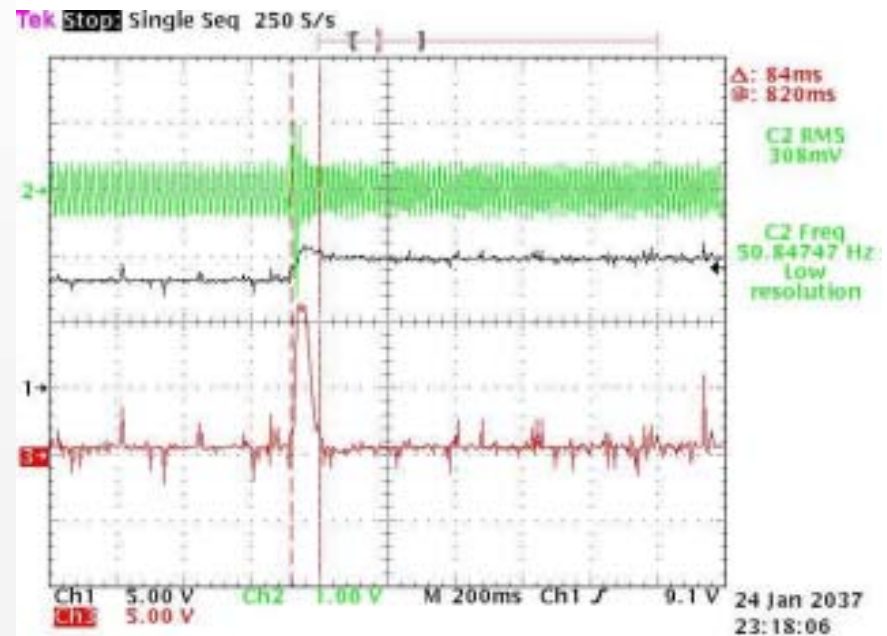

G5 (Sensorless)

Thank you ! !