

3RW Soft Starters

General data

Overview

The advantages of the SIRIUS soft starters at a glance:

- Soft starting and smooth ramp-down¹⁾
- Stepless starting
- Reduction of current peaks
- Avoidance of mains voltage fluctuations during starting
- Reduced load on the power supply network

- Reduction of the mechanical load in the operating mechanism
- Considerable space savings and reduced wiring compared with conventional starters
- Maintenance-free switching
- Very easy handling
- Fits perfectly in the SIRIUS modular system



		SIRIUS 3RW30/31 Standard applications	SIRIUS 3RW40	SIRIUS 3RW44 High-Feature applications
Rated current up to 40 °C	A	3 ... 100	134 ... 432	29 ... 1214
Rated operational voltage	V	200 ... 575	200 ... 600	200 ... 690
Motor rating at 400 V				
• Inline circuit	kW	1.1 ... 55	75 ... 250	15 ... 710
• Inside-delta circuit	kW	–	–	22 ... 1200
Temperature range	°C	-25 ... +60	-25 ... +60	0 ... +60
Soft starting/ramp-down		✓ ¹⁾	✓	✓
Voltage ramp		✓	✓	✓
Starting/stopping voltage	%	40 ... 100	40 ... 100	20 ... 100
Starting and ramp-down time	s	0 ... 20	0 ... 20	1 ... 360
Torque control		–	–	✓
Starting/stopping torque	%	–	–	20 ... 100
Torque limit	%	–	–	20 ... 200
Ramp time	s	–	–	1 ... 360
Integral bypass contact system		✓ ²⁾	✓	✓
Intrinsic device protection		–	✓	✓
Motor overload protection		–	✓	✓
Thermistor motor protection		–	–	✓
Adjustable current limiting		–	✓	✓
Inside-delta circuit		–	–	✓
Breakaway pulse		–	–	✓
Creep speed in both directions		–	–	✓
Pump ramp-down		–	–	✓ ⁷⁾
DC braking		–	–	✓ ³⁾⁷⁾
Combined braking		–	–	✓ ³⁾⁷⁾
Motor heating		–	–	✓ ⁴⁾
Communication		–	–	with PROFIBUS DP ⁴⁾ (option)
External display and operator module		–	–	(option ⁴⁾)
Operating measured value display		–	–	✓
Error logbook		–	–	✓ ⁴⁾
Event list		–	–	✓ ⁴⁾
Slave pointer function		–	–	✓ ⁴⁾
Trace function		–	–	✓ ⁵⁾
Programmable control inputs and outputs		–	–	✓
Number of parameter sets		1 (2 with 3RW31)	1	3
Parameterization software (Soft Starter ES)		–	–	✓ ⁴⁾
Power semiconductors (thyristors)		–	2 controlled phases	3 controlled phases
Spring-loaded terminals		✓ (only 3RW30 03)	–	–
Screw terminals		✓	✓	✓
UL/CSA		✓ ⁶⁾	✓	✓
CE marking		✓	✓	✓
Soft starting under heavy starting conditions		–	–	✓ ⁷⁾
Configuring support		Win-Soft Starter, the electronic selection slider ruler, Technical Assistance ++49 911 895 5900		

- ✓ Function is available
- Function not available

1) Only soft starting available for 3RW31.
 2) Not available for 3RW30 03.
 3) Not possible in inside-delta circuit.
 4) Start of delivery 2006.

5) Trace function with Soft Starter ES software.
 6) For 3RW30 03 up to 230 V.
 7) Calculate soft starter and motor with size allowance where required.

More information can be found on the Internet at
<http://www.siemens.com/sanftstarter>

Overview

Various versions of the 3RW30/31 SIRIUS soft starters are available:

- Standard version for fixed frequency three-phase motors, sizes S00, S0, S2 and S3
- Version for fixed-speed three-phase motors in a 22.5 mm enclosure
- Special-purpose version 3RW31 for Dahlander motors only in size S0
- Version for soft starting single-phase motors of sizes S0, S2 and S3.

SIRIUS 3RW30/31 for three-phase motors

Soft starters rated up to 55 kW (at 400 V) for standard applications in three-phase networks. Extremely small sizes, low power losses and simple commissioning are just a few of the many advantages of this soft starter. The special feature of the 3RW31 series is that it allows independent definition of two separate acceleration ramps (Dahlander motors).

SIRIUS 3RW30 for single-phase motors

The additional version for standard applications in single-phase networks. Its voltage edge function reduces the motor's inrush current and effectively lowers the torque at the point of starting up. The load and the supplying network are thus protected.

Function

- Soft starting with voltage ramp; the starting voltage setting range U_s is 40 % to 100 % and the ramp time t_R can be set from 0 s to 20 s.
- Smooth ramp-down with voltage ramp; the running down time t_{off} can be set between 0 s to 20 s. The switch-off voltage U_{off} is then dependent on the selected starting voltage U_s .
- Setting with three potentiometers
- Simple mounting and commissioning
- Mains voltages at 50/60 Hz 200 to 575 V
- Two control voltage versions 24 V UC and 110 to 230 V UC
- Wide temperature range from -25 °C to +60 °C
- Integrated bypass contacts to minimize dissipated power.
- Two built-in auxiliary contacts in sizes S0, S2 and S3 ensure user-friendly control and possible further processing within the system (see status graphs on page 6/11).

Technical specifications

Type		3RW30 03	3RW3 ...-1.B0.	3RW3 ...-1.B1.
Control electronics				
• Rated control supply voltage	V	24 ... 230 AC/DC (±10 %)	24 AC/DC (+10 %/-15 %)	110 ... 230 AC/DC (+10 %/-15 %)
• Rated control supply current Without fan/with fan	mA	25 ... 4	Approx. 50/ Approx. 180	Approx. 25 ... 20 / Approx. 85 ... 80
• Rated frequency for AC	Hz	50/60 ±10 %		
• Starting time	s	0.1 ... 20 (adjustable)		
• Starting voltage	%	40 ... 100 (adjustable)		
• Ramp-down time	s	0 ... 20 (adjustable)		

Type		3RW3003	3RW3 ...-1.B.4	3RW3 ...-1.B.5	3RW30 ...-1AA12
Power electronics					
Rated operational voltage	V	200 ... 400, AC 3-phase (±10 %)	200 ... 460, AC 3-phase (±10 %)	460 ... 575, AC 3-phase (+10 %/-15 %)	115 ... 240, AC 1-phase (±10 %)
Rated frequency	Hz	50 ... 60 ±10 %			
Permissible installation altitude	Reduction of I_e				
	• Up to 1000 m above sea level	%	100		
	• Up to 2000 m above sea level	%	92		
	• Up to 3000 m above sea level	%	85		
	• Up to 4000 m above sea level ¹⁾	%	78		
Mounting position	Without auxiliary fan	The soft starters have been designed for operation on a vertical mounting surface (+10°/-10°).			
	With auxiliary fan	-- Any mounting position (except vertical, rotated by 180°)			

1) At an altitude from 2000 m, the max. permissible operational voltage for all 3RW30 is reduced to 460 V.

3RW Soft Starters

3RW30, 3RW31 for standard applications

Type		3RW30 03	3RW30 1. S00	3RW30 2. S0	3RW30 3. S2	3RW30 4. S3	
Size							
Continuous operation (% of I_e)	%	100					
Minimum load ¹⁾ (% von I_e); at 40 °C	%	9	4				
Permissible ambient temperature							
• Operation	°C	-25 ... +60 (derating from 40 °C, see load rating)					
• Storage	°C	-25 ... +80					
Switching capacity of the auxiliary contacts		230 V/AC-15	A	No auxiliary contacts available	3	3	3
		230 V/DC-13	A		0.1	0.1	0.1
		24 V/DC-13	A		1	1	1

1) The rated motor current (specified on the motor's name plate) should at least amount to the specified percentage of the SIRIUS soft starter unit's rated operational current I_e .

Type		3RW30 03	3RW30 14	3RW30 16	3RW3 . 24	3RW3 . 25	3RW3 . 26	
Load capacity								
Rated operational current I_e								
• According to IEC for individual mounting	at 40/50/60 °C, AC-53b	A	--	6/5/4	9/8/7	12.5/11/9	16/14/12	25/21/18
• According to UL/CSA for individual mounting	at 40/50/60 °C, AC-53b	A	--	4.8/4.8/4	7.8/7.8/7	11/11/9	17.5/14/12	25/21/18
• According to IEC/UL/CSA for individual mounting	at 40/50/60 °C, AC-53a	A	3 / 2.6 / 2.2	--				
• According to IEC/UL/CSA for butt-mounting	at 40/50/60 °C, AC-53a	A	2.6 / 2.2 / 1.8	--				
Power loss								
At uninterrupted rated operational current (40 °C) approx.	W	6.5	5	7	7	9	13	
At utilization of max. operating frequency	W	3	5	6	7	8	9	
Permissible starts per hour when not using a fan								
• For intermittent duty S4, $T_u = 40$ °C, stand-alone installation vertical	1/h	1500	60	40	30		12	
• ON-period = 30 %	% I_e /s	--	250/2		300/2			
• ON-period = 70 %	% I_e /s	300/0.2	--					
Permissible starts per hour when using a fan	1/h	Fans cannot be fitted			54		21	
For intermittent duty S4, $T_u = 40$ °C, ON-period = 30 %; stand-alone installation								
Pause intervals after continuous duty	s	0						
With I_e before a new start								
Degree of protection	according to IEC 60529	IP20 (IP00 terminal enclosure)						
Maximum conductor length between soft starter and motor	m	100 ¹⁾						
Conductor cross-sections								
Screw terminals (1 or 2 conductors connectable) For standard screwdriver size 2 and Pozidriv 2								
• Main conductors								
- Solid	mm ²	1 x (0.5 ... 4);	2 x (0.5 ... 1.5);		2 x (1 ... 2.5) 2 x (2.5 ... 6)			
		2 x (0.5 ... 2.5)	2 x (0.75 ... 2.5)					
- Finely stranded with end sleeve	mm ²	1 x (0.5 ... 2.5);	2 x (0.5 ... 2.5)		2 x (1 ... 2.5) 2 x (2.5 ... 6)			
- Stranded	mm ²	2 x (0.5 ... 1.5)						
- AWG conductors, solid or stranded	AWG	2 x (20 ... 14)	2 x (18 ... 14)		2 x (14 ... 10)			
- Terminal screws		M3, PZ2	M3, PZ2		M4, PZ2			
- Tightening torque	Nm lb.in	0.8 ... 1.2 7.1 ... 8.9	7 ... 10.3		2 ... 2.2 18 ... 22			
• Auxiliary conductors								
- Solid	mm ²	1 x (0.5 ... 4);	2 x (0.5 ... 1.5) 2 x (0.75 ... 2.5)		according to IEC 60947;			
		2 x (0.5 ... 2.5)	max. 2 x (0.75 ... 4)					
- Finely stranded with end sleeve	mm ²	1 x (0.5 ... 2.5)	2 x (0.5 ... 1.5) 2 x (0.75 ... 2.5)					
- Stranded	mm ²	2 x (0.5 ... 1.5)						
- AWG conductors, solid or stranded	AWG	2 x (20 ... 14)	2 x (18 ... 14)					
- Terminal screws		M3, PZ2						
- Tightening torque	Nm lb.in	0.8 ... 1.2 7 ... 8.9	0.8 ... 1 7.1 ... 8.9					
Spring-loaded terminals								
Main and auxiliary conductors								
• Solid	mm ²	2 x (0.25 ... 1.5)	--					
• Finely stranded with end sleeve	mm ²	2 x (0.25 ... 1)	--					
• AWG conductors, solid or stranded	mm ²	2 x (24 ... 16)	--					

1) If this value is exceeded, problems with line capacities may arise, which can result in false firing.

Type		3RW30 34	3RW30 35	3RW30 36	3RW30 44	3RW30 45	3RW30 46	
Power electronics								
Load rating								
With rated operational current I_e								
• According to IEC for individual mounting	at 40/50/60 °C, AC-53b	A	32/27/23	38/32/27	45/38/32	63/54/46	75/64/54	100/85/72
• According to UL/CSA for individual mounting	at 40/50/60 °C, AC-53b	A	27/27/23	34/32/27	42/38/32	62/54/46	68/64/54	99/85/72
Power loss								
• At uninterrupted rated operational current (40 °C) approx.		W	10	13	17	13	16	26
• (40 °C) at utilization of max. operating frequency		W	11	11	10	18	29	26
Permissible starts per hour when not using a fan								
• For intermittent duty S4, $T_u = 40$ °C, stand-alone installation vertical	1/h		20	15	5	20	30	15
• ON-period = 30 %	% I_e/s		300 /3			300 /4		
Permissible starts per hour when using a fan								
For intermittent duty S4, $T_u = 40$ °C, ON-period = 30%; stand-alone installation	1/h		44	27	9	32	48	24
Pause intervals after continuous duty								
With I_e before a new start	s		0		400	0		
Degree of protection								
according to IEC 60529			IP20 (IP00 terminal enclosure)			IP20 ¹⁾		
Maximum conductor length between soft starter and motors								
	m		100					
Conductor cross-sections								
Screw terminals (1 or 2 conductors connectable) For standard screwdriver size 2 and Pozidriv 2								
• Main conductors:								
- Solid	mm ²		2 x (0.75 ... 16)					
- Finely stranded with end sleeve	mm ²		2 x (0.75 ... 16) 1 x (0.75 ... 25)					
- Stranded	mm ²		2 x (0.75 ... 25) 1 x (0.75 ... 35)					
- AWG conductors, solid or stranded	AWG		2 x (18 ... 3) 1 x (18 ... 2)					
- Terminal screws	Nm		M6, box terminal, PZ2					
- Tightening torque	lb.in		3 ... 4.5 27 ... 40					
• Auxiliary conductors:								
- Solid	mm ²		2 x (0.5 ... 1.5) 2 x (0.75 ... 2.5) accord. to IEC 60947; max. 2 x (0.75 ... 4)					
- Finely stranded with end sleeve	mm ²		2 x (0.5 ... 1.5) 2 x (0.75 ... 2.5)					
- AWG conductors, solid or stranded	AWG		2 x (18 ... 14)					
- Terminal screws	Nm		M3					
- Tightening torque	lb.in		0.8 ... 1 7.1 ... 8.9					

- 1) IP20 only with installed box terminal ('as-delivered'). Without box terminal IP00.
- 2) If this value is exceeded, problems with line capacities may arise, which can result in false firing.

	Standard	Parameters
Electromagnetic compatibility according to EN 60947-4-2		
EMC interference immunity		
Electrostatic discharge (ESD)	IEC 61000-4-2	Degree of severity 3: 6/8 kV
Electromagnetic RF fields	IEC 60947-4-2	Frequency range: 80 to 1000 MHz with 80 % at 1 kHz Degree of severity 3, 10 V/m
Conducted RF interference	IEC 61000-4-6 IEC 60947-4-2 SN-IACS	Frequency range: 80 to 1000 MHz with 80 % at 1 kHz 10 V at 0.15 ... 80 MHz 3 V at 10 kHz ... 80 MHz
Burst Surge	IEC 61000-4-4 IEC 61000-4-5	Degree of severity 3: 1/2 kV Degree of severity 3: 1/2 kV
EMC interference emission		
EMC interference field strength	CISPR 11/09. 1990	Limit value of Class B at 30 to 1000 MHz
Radio interference voltage	CISPR 11/09. 1990 IEC 60947-4-2	(0.15 ... 30 MHz): Unit Class A (industry)



3RW Soft Starters

3RW30, 3RW31 for standard applications

Is an RI suppression filter necessary?

	24 V AC/DC control voltage		110 ... 240 V AC/DC control voltage	
	Main circuit	Control circuit	Main circuit	Control circuit
Degree of noise suppression A (industrial applications)	No	No	No	No
Degree of noise suppression B (applications for residential areas)	No	No	Yes ²⁾ (see table Recommended Filters)	Yes ¹⁾²⁾

- 1) "No" only applies if the control voltage is taken from the main circuit downstream of the RI suppression filter.
- 2) It may be preferable to use a device with 24 V AC/DC control voltage here; in that case the control voltage must be adapted with a transformer.

Soft starter type	Rated current Soft starters A	Recommended filters					
		Voltage range 200 ... 460 V			Voltage range 460 ... 575 V		
		Filter type	Rated current filter A	Terminals mm ²	Filter type	Rated current filter A	Terminals mm ²
3RW30 14	6	B84143-G8-R110	8	4	--	--	--
3RW30 16	9	B84143-G20-R110	20	4	--	--	--
3RW30 24	12.5	B84143-G20-R110	20	4	B8413-A25-R21	25	10
3RW30 25	16	B84143-G20-R110	20	4	B8413-A25-R21	25	10
3RW30 26	25	B84143-G36-R110	36	6	B8413-A25-R21	25	10
3RW30 34	32	B84143-G36-R110	36	6	B8413-A36-R21	36	10
3RW30 35	38	B84143-G36-R110	36	6	B8413-A36-R21	36	10
3RW30 36	45	B84143-G50-R110	50	6	B8413-A50-R21	50	10
3RW30 44	63	B84143-G66-R110	66	25	B8413-A80-R21	80	25
3RW30 45	75	B84143-G120-R110	120	50	B8413-A80-R21	80	25
3RW30 46	100	B84143-G120-R110	120	50	B8413-A120-R21	120	50

Fuse assignment

The coordination type to which the motor feeder with soft starter is mounted depends on the application-specific requirements. Normally, fuseless mounting (combination of circuit-breaker and soft starter) is sufficient. If type 2 coordination is to be fulfilled, semiconductor fuses must be fitted in the motor feeder.

Fuseless version

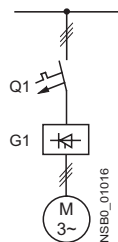

Soft starters Type G1	Motor starter protectors ¹⁾ Type Q1	Link modules ²⁾ Type
Coordination type 1³⁾ : I_q = 50 kA at 400 V		
3RW30 03	3RV10 11	--
3RW30 14	3RV10 11	3RA19 11-1A
3RW30 16	3RV10 11	3RA19 11-1A
3RW30 24/3RW31 24	3RV10 21	3RA19 21-1A
3RW30 25/3RW31 25	3RV10 21	3RA19 21-1A
3RW30 26/3RW31 26	3RV10 21	3RA19 21-1A
3RW30 34	3RV10 31	3RA19 31-1A
3RW30 35	3RV10 31	3RA19 31-1A
3RW30 36	3RV10 31	3RA19 31-1A
3RW30 44	3RV10 41	3RA19 41-1A
3RW30 45	3RV10 41	3RA19 41-1A
3RW30 46	3RV10 41	3RA19 41-1A

- 1) The rated motor current must be considered when selecting the devices.
- 2) Pay attention to quantity units.
- 3) The types of coordination are explained in more detail under Fuseless Load Feeders on page 6/48.

Fused version (line protection only)

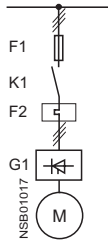

Soft starters	Line protections			Overload relays		Contactors
	Type	Rated current	Size	Thermal	Solid-state	
G1	F1	A		F2	Type	K1
Type of coordination 1: ¹⁾ I_q = 50 kA at 400 V						
3RW30 03	3NA3 805 ²⁾	20	000	3RU11 16	3RB10 16	3RT10 15
3RW30 14	3NA3 807	20	000	3RU11 16 ³⁾	3RB10 16 ³⁾	3RT10 15
3RW30 16	3NA3 807	20	000	3RU11 16 ³⁾	3RB10 16 ³⁾	3RT10 16
3RW30 24/3RW31 24	3NA3 807	20	000	3RU11 26 ⁴⁾	3RB10 26 ⁴⁾	3RT10 24
3RW30 25/3RW31 25	3NA3 810	25	000	3RU11 26 ⁴⁾	3RB10 26 ⁴⁾	3RT10 25
3RW30 26/3RW31 26	3NA3 814	35	000	3RU11 26 ⁴⁾	3RB10 26 ⁴⁾	3RT10 26
3RW30 34	3NA3 822	63	000	3RU11 36 ⁴⁾	3RB10 36	3RT10 34
3RW30 35	3NA3 822	63	000	3RU11 36 ⁴⁾	3RB10 36	3RT10 35
3RW30 36	3NA3 824	80	000	3RU11 36 ⁴⁾	3RB10 36	3RT10 36
3RW30 44	3NA3 830	100	000	3RU11 46 ⁴⁾	3RB10 46	3RT10 44
3RW30 45	3NA3 132	125	1	3RU11 46 ⁴⁾	3RB10 46	3RT10 45
3RW30 46	3NA3 140	200	1	3RU11 46 ⁴⁾	3RB10 46	3RT10 46

1) The types of coordination are explained in more detail under Fuseless Load Feeders on page 6/48.

2) 3NA38 05-1 (NH00), 5SB26 1 (DIAZED), 5SE22 01-6 (NEOZED).

3) I_q = 50 kA up to max. 400 V

4) I_q = 50 kA up to max. 500 V

Fused version with 3NE1 SITOR fuses (semiconductor and line protection)¹⁾

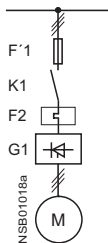

Soft starters	All-range fuses			Max.		
	Type	Rated current	Size	Type	Rated current	Size
G1	F'1	A		F'1	A	
Type of coordination 2²⁾ : I_q = 50 kA at 400 V/500 V						
3RW30 03	3NE1 813-0 ³⁾	16	000	3NE1 813-0 ³⁾	16	000
3RW30 14	3NE1 813-0 ³⁾	16	000	3NE1 814-0 ⁴⁾	20	000
3RW30 16	3NE1 813-0 ³⁾	16	000	3NE1 815-0 ⁵⁾	25	000
3RW30 24/3RW31 24	3NE1 814-0 ⁴⁾	20	000	3NE1 815-0 ⁵⁾	25	000
3RW30 25/3RW31 25	3NE1 815-0 ⁵⁾	25	000	3NE1 815-0 ⁵⁾	25	000
3RW30 26/3RW31 26	3NE1 803-0 ⁵⁾	35	000	3NE1 802-0 ⁵⁾	40	000
3RW30 34	3NE1 817-0 ⁵⁾	50	000	3NE1 818-0 ⁵⁾	63	000
3RW30 35	3NE1 818-0 ⁵⁾	63	000	3NE1 820-0 ⁵⁾	80	000
3RW30 36	3NE1 818-0 ⁵⁾	63	000	3NE1 820-0 ⁵⁾	80	000
3RW30 44	3NE1 820-0 ⁵⁾	80	000	3NE1 820-0 ⁵⁾	80	000
3RW30 45	3NE1 021-0 ⁵⁾	100	00	3NE1 021-0 ⁵⁾	100	00
3RW30 46	-- ⁶⁾	--	--	-- ⁶⁾	--	--

1) Contactor and overload relay as in "Fused version (line protection only)" table.

2) The types of coordination are explained in more detail under Fuseless Load Feeders on page 6/48.

3) No SITOR fuse required!
Alternatively: 3NA38 03 (NH00), 5SB22 1 (DIAZED), 5SE22 06 (NEOZED).

4) Fuse coordination for up to 400 V.

5) Fuse coordination for up to 500 V.

6) Fuse coordination with all-range fuses not possible; it may be necessary to use a pure semiconductor protection fuse plus a motor starter protector.

3RW Soft Starters

3RW30, 3RW31 for standard applications

Fused versions with 3NE8 SITOR fuses

(semiconductor protection by fuse, lead and overload protection by motor starter protector; alternatively, installation with contactor and overload relay possible)



Soft starters	Solid-state protection fuses						Semiconductor fuses (cylinder)					
	Min. Type	Rated current	Size	Max. Type	Rated current	Size	Min. Type	Rated current	Size	Max. Type	Rated current	Size
G1	F3	A		F3	A		F3	A	mm x mm	F3	A	mm x mm

Type of coordination 2 ¹⁾ : I _q = 50 kA at 400 V												
3RW30 03	3NE8 015-1	25	00	3NE8 015-1	25	00	3NC1 006	6	10 x 38	3NC1 010	10	10 x 38
3RW30 14	3NE8 015-1	25	00	3NE8 003-1	35	00	3NC1 006	6	10 x 38	3NC1 430	30	14 x 51
3RW30 16	3NE8 015-1	25	00	3NE8 003-1	35	00	3NC1 010	10	10 x 38	3NC1 430	30	14 x 51
3RW30 24/3RW31 24	3NE8 015-1	25	00	3NE8 003-1	35	00	3NC1 016	16	10 x 38	3NC1 430	30	14 x 51
3RW30 25/3RW31 25	3NE8 015-1	25	00	3NE8 003-1	35	00	3NC1 025	25	10 x 38	3NC1 430	30	14 x 51
3RW30 26/3RW31 26	-- ²⁾	--	--	-- ²⁾	--	--	-- ²⁾	--	--	-- ²⁾	--	--
3RW30 34	3NE8 002-1	63	00	3NE8 022-1	125	00	3NC1 450	50	14 x 51	3NC2 280	80	22 x 58
3RW30 35	3NE8 020-1	80	00	3NE8 024-1	160	00	3NC2 263	63	22 x 58	3NC2 200	100	22 x 58
3RW30 36	3NE8 021-1	100	00	3NE8 024-1	160	00	3NC2 280	80	22 x 58	3NC2 200	100	22 x 58
3RW30 44	3NE8 021-1	100	00	3NE8 024-1	160	00	3NC2 200	100	22 x 58	3NC2 200	100	22 x 58
3RW30 45	3NE8 022-1	125	00	3NE8 024-1	160	00	-- ²⁾	--	--	-- ²⁾	--	--
3RW30 46	3NE8 024-1	160	00	3NE8 024-1	160	00	-- ²⁾	--	--	-- ²⁾	--	--

Soft starters	Motor starter protectors ³⁾	Link modules ⁴⁾	Overload relays		Contactors
Type	Type	Type	Thermal Type	Solid-state Type	Type
G1	Q1		F2		K1

Type of coordination 2 ¹⁾ : I _q = 50 kA at 400 V					
3RW30 03	3RV10 11 ⁵⁾	3RA19 11-1A	3RU11 16	3RB10 16	3RT10 15
3RW30 14	3RV10 11	3RA19 11-1A	3RU11 16	3RB10 16	3RT10 15
3RW30 16	3RV10 11	3RA19 11-1A	3RU11 16	3RB10 16	3RT10 16
3RW30 24/3RW31 24	3RV10 21	3RA19 21-1A	3RU11 26	3RB10 26	3RT10 24
3RW30 25/3RW31 25	3RV10 21	3RA19 21-1A	3RU11 26	3RB10 26	3RT10 25
3RW30 26/3RW31 26	3RV10 21	3RA19 21-1A	3RU11 26	3RB10 26	3RT10 26
3RW30 34	3RV10 31	3RA19 31-1A	3RU11 36	3RB10 36	3RT10 34
3RW30 35	3RV10 31	3RA19 31-1A	3RU11 36	3RB10 36	3RT10 35
3RW30 36	3RV10 31	3RA19 31-1A	3RU11 36	3RB10 36	3RT10 36
3RW30 44	3RV10 41	3RA19 41-1A	3RU11 46	3RB10 46	3RT10 44
3RW30 45	3RV10 41	3RA19 41-1A	3RU11 46	3RB10 46	3RT10 45
3RW30 46	3RV10 41	3RA19 41-1A	3RU11 46	3RB10 46	3RT10 46

- The types of coordination are explained in more detail under Fuseless Load Feeders on page 6/48.
- Fuse coordination with semiconductor fuses not possible; it may be necessary to use pure 3NE1 all-range fuses or the next highest soft starter.
- The rated motor current defines the selection of devices.
- Pay attention to quantity units.
- No SITOR fuse required!
Alternatively: 3NA38 03 (NH00), 5SB22 1 (DIAZED), 5SE22 06 (NEOZED).

More information

Configuration

The 3RW solid-state motor controllers are designed for easy starting conditions. In the event of deviating conditions or increased switching frequency, it may be necessary to choose a larger device. For accurate dimensioning, use the Win-Soft Starter selection and simulation program.

If necessary, an overload relay for heavy-starting must be selected where long starting times are involved. PTC sensors are recommended. This also applies for the smooth ramp-down because during the ramp-down time an additional current loading applies in contrast to free ramp-down.

In the motor feeder between the SIRIUS 3RW soft starter and the motor, no capacitive elements are permitted (e.g. no reactive-power compensation equipment). In addition, neither static systems for reactive-power compensation nor dynamic PFC (Power Factor Correction) must be operated in parallel during starting and ramp-down of the soft starter. This is important to prevent faults arising on the compensation equipment and/or the soft starter.

All elements of the main circuit (such as fuses, controls and overload relays) should be dimensioned for direct starting, following the local short-circuit conditions. Fuses, switching devices and overload relays must be ordered separately. Please observe the maximum switching frequencies specified in the technical specifications.

Power electronics circuit diagram¹⁾

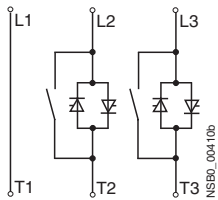

Status graphs

3RW30 – 3-ph. mot.

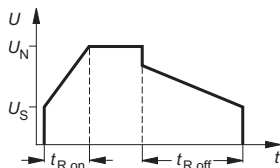

Auxiliary contacts (sizes S0 to S3 only)

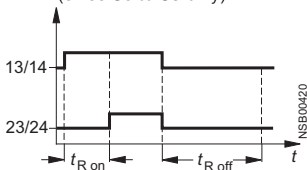

3RW31

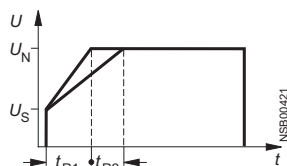

1) Circuit diagram applies to sizes S0 and S2;
for size S00, phase L3 is bridged;
for size S3, phase L2 is bridged.

Control with a PLC

When a 3RW30 is operated with a Triac output or thyristor output, the leakage current at the PLC output should be < 1 mA because otherwise the 3RW30 will interpret the resultant voltage drop at the input as an "On command". As a corrective measure for PLC outputs with a higher leakage current, an RC element with > 100 nF and 220 W can be connected in series between "IN1" and terminal "A2" of the 3RW30 (Order No.: 3TX7 462-3T see Selection and Ordering Data).

Win-Soft Starter selection and simulation program

With this software, you can simulate and select all Siemens soft starters, taking into account various parameters such as mains properties, motor and load data, and special application requirements.

The software is a valuable tool, which makes complicated, lengthy manual calculations for determining the required soft starters superfluous.

You can order the CD-ROM under the following order number:

Order No. E20001-D1020-P302-V2-7400.

You can find more information on the Internet at:

<http://www.siemens.com/softstarter>

3RW40 for standard applications

Overview

SIRIUS 3RW40 soft starters have all the same advantages as the 3RW30/31 soft starters. At the same time they come with additional functions, e.g. solid-state motor overload and intrinsic device protection and adjustable current limiting, as well as a two-phase control method (Polarity Balancing) that is unique in this rating range.

SIRIUS 3RW40 soft starters are part of the SIRIUS modular system. This results in advantages such as identical sizes and a uniform connection system. Thanks to their particularly compact design, SIRIUS 3RW40 soft starters are only half as big as comparable wye-delta starters. Hence they can be mounted in minimum space in the control cabinet. Configuring and mounting are carried out quickly and easily thanks to the 3-wire connection.

SIRIUS 3RW40 for three-phase motors

Soft starters rated up to 250 kW (at 400 V) for standard applications in three-phase networks. Extremely small sizes, low power losses and simple commissioning are just three of the many advantages of the SIRIUS 3RW40 soft starters.

Function

SIRIUS 3RW40 soft starters have all the same advantages as the 3RW30/31 soft starters. At the same time they come with additional functions and a two-phase control method (Polarity Balancing) that is unique in the rating range up to 250 kW. Starting voltage, starting and ramp-down time of the voltage ramp and current limit are all easy to set using stepless rotary potentiometers, the same as on the SIRIUS 3RW30/31. The rated motor current, the setting of the tripping time and the resetting of the motor overload function are controlled like the SIRIUS overload relays by means of potentiometers and keys. Once again there is nothing new to get used to.

SIRIUS 3RW40 comes with the new, patented control method called "Polarity Balancing", which is designed to prevent DC current components in two-phase controlled soft starters. On two-phase controlled soft starters the current resulting from superimposition of the two controlled phases flows in the uncontrolled phase. This results for physical reasons in an asymmetric distribution of the three phase currents during the starting operation of the motor. This phenomenon cannot be influenced, but in most applications it is non-critical. Controlling the power semiconductor in the two controlled phases results not only in this asymmetry, however, but also in the previously mentioned direct current components which can cause severe noise generation on the motor at starting voltages of less than 50 %. "Polarity Balancing" reliably eliminates these DC current components during the ramp-up phase. It creates a motor ramp-up that is uniform in speed, torque and current rise. At the same time the acoustic quality of the starting operation comes close to the quality of a three-phase controlled starting operation. This is made possible by the on-going dynamic balancing of current half-waves of different polarity during the motor ramp-up.

The SIRIUS 3RW40 is equipped with optimum functionality. An integral bypass contact system reduces the power loss of the soft starter during operation. This reliably prevents heating of the switchgear environment. Using a 4-step rotary potentiometer it is possible to set different overload tripping times. Thanks to the integral motor overload protection to IEC 60947-4-2 there is no need of an additional overload relay. This saves space in the control cabinet and wiring work in the feeder. Internal intrinsic device protection prevents in addition the thermal overloading of the thyristors and the power section defects this can cause.

As an option the thyristors can also be protected by SITOR semiconductor fuses from short-circuiting. And even inrush current peaks are reliably avoided thanks to adjustable current limiting. Three LEDs are used to indicate the operating status as well as possible errors, e.g. non-permissible tripping time (CLASS setting), mains or phase failure, missing load, thermal overloading or device faults.

We offer a comprehensive range of accessories for our soft starters. Examples include box terminal blocks, accessories for mechanical reset and a module for remote reset, a sealing cover or easy-to-fit terminal covers for optimum touch protection.

- Soft starting with voltage ramp; the starting voltage setting range U_s is 40 to 100 % and the ramp time t_R can be set from 0 to 20 s.
- Smooth ramp-down with voltage ramp; the running down time t_{off} can be set between 0 s to 20 s. The switch-off voltage U_{off} is then dependent on the selected starting voltage U_s .
- Solid-state motor overload and intrinsic device protection
- Adjustable current limiting
- Integrated bypass contact system to minimize dissipated power
- Setting with three potentiometers
- Simple mounting and commissioning
- Mains voltages 50/60 Hz, 200 to 600 V
- Two control voltage versions 115 V AC and 230 V AC. Control by way of the internal 24 V DC supply and direct control by means of PLC are possible.
- Wide temperature range from -25 to +60 °C
- Built-in auxiliary contacts ensure user-friendly control and possible further processing within the system (for status graphs see page 6/21)

Technical specifications

Type	3RW40 5.		3RW40 7.	
Control electronics				
Rated values	Terminal A1/A2	V AC	115	230
Rated control supply voltage		%	-15/+10	-15/+10
• Tolerance				
Rated control supply current STANDBY		mA	15	15
Rated control supply current ON ¹⁾		mA	440	660
Rated frequency		Hz	50/60	50/60
• Tolerance		%	±10	±10
Control inputs				
IN			ON/OFF	
Rated operational current		mA	Approx. 10 according to DIN 19240	
Rated operational voltage		V DC	24 from internal supply dc+ or external DC supply (according to DIN 19240) through terminals and IN	
Relay outputs				
Output 1	ON/RUN mode ²⁾	13/14	Operating indication	
Output 2	BYPASSED	23/24	Bypass indication	
Output 3	OVERLOAD/ FAILURE	95/96/97	Overload/error indication	
Rated operational current		A	3 AC-15/AC-14 at 230 V	
Rated operational voltage			1 DC-13 at 24 V	
Protection against overvoltages			Protection by means of varistor through contact	
Short-circuit protection			4 A gL/gG operational class; 6 A quick (fuse is not included in scope of supply)	

1) Values for the coil power consumption at +10 % U_n , 50 Hz.

2) Factory presetting: ON mode.

Type	3RW40 ..				
Control electronics					
Operating indications	LED	DEVICE	STATE/BYPASSED	FAILURE	OVERLOAD
Off		Green	Off	Off	Off
Start		Green	Green flashing	Off	Off
Bypass		Green	Green	Off	Off
Ramp-down		Green	Green flashing	Off	Off
Alarm indications					
I_e /class setting not permissible		Off	Not relevant	Not relevant	Red flashing
Start inhibited/thyristors too hot		Yellow flashing	Not relevant	Not relevant	Off
Error signals					
$U < 0.75 \times U_s$ or $U > 1.15 \times U_s$		Off	Off	Red	Off
Non-permissible I_e /Class setting for edge 0 → 1 on input IN		Green	Off	Red	Red flashing
Motor protection shut-down		Green	Off	Off	Red
Thermal overloading of the thyristors		Yellow	Off	Red	Off
Missing mains voltage, phase failure, missing load		Green	Off	Red	Off
Device error		Red	Off	Red	Off

Type	3RW40 ..		Factory presetting
Protective functions			
Motor protection functions			
Trips in the event of		Thermal overloading of the motor	
Trip class to IEC 60947-4-1	Class	10/15/20	10
Phase loss sensitivity	%	> 40	
Overload warning		No	
Reset option after tripping		Manual/automatic (MAN/AUTO)	
Recovery time	min	5	
Device protection functions			
Trips in the event of		Thermal overloading of the thyristors	
Reset option after tripping		Manual/automatic (MAN/AUTO)	
Recovery time	s	30	

3RW Soft Starters

3RW40 for standard applications

Type	3RW40 ..			Factory presetting
Control times and parameters				
Control times				
Closing delay (with connected control voltage)	ms	<50		
Closing delay (automatic/mains contactor mode)	ms	<300		
Recovery time (closing command in active ramp-down)	ms	100		
Mains failure bridging time				
Control supply voltage	ms	50		
Mains failure response time				
Load current circuit	ms	500		
Reclosing lockout after overload trip				
Motor protection trip	min	5		
Device protection trip	s	30		
Starting parameters				
Starting time	s	0 ... 20	7	
Starting voltage	%	40 ... 100	50	
Starting current limit		1.3 ... 5 x I _e	5 x I _e	
Ramp-down parameters				
Ramp-down time	s	0 ... 20	0	
Reset mode parameters (for motor/device protection shut-down)				
Manual reset	LED AUTO	Off	Off	
Automatic reset	LED AUTO	Yellow		
Start-up detection				
		Yes		
Operating mode output 13/14				
Rising edge at	Start command			
Falling edge at	Off command			ON
	Ramp-down end	ON		

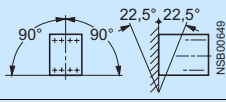





Type	3RW40 ...BB4.		3RW40 ...BB5.
Power electronics			
Rated operational voltage for inline circuit	V AC	200 ... 460	400 ... 600
Tolerance	%	-15/+10	-15/+10
Rated frequency	Hz	50/60	
Tolerance	%	±10	
Continuous operation at 40 °C (% of I _e)	%	115	
Minimum load (% of I _e)	%	20	
Maximum conductor length between soft starter and motor	m	200	
Permissible installation height	m	2000 (derating from 1000); higher on request	
Permissible mounting position			
Permissible ambient temperature			
Operation	°C	-25 ... +60; (derating from +40)	
Storage	°C	-40 ... +80	
Degree of protection		IP00	

Type		3RW40 55	3RW40 56	3RW40 73	3RW40 74	3RW40 75	3RW40 76
Power electronics							
Load rating with rated operational current I_e According to IEC and UL/CSA for individual mounting at 40/50/60 °C, AC-53a	A	134/117/100	162/145/125	230/205/180	280/248/215	356/315/280	432/385/335
Smallest adjustable rated motor current I_M For the motor overload protection	A	59	87	80	130	131	207
Power loss At uninterrupted rated operational current (40 °C) approx.	W	60	75	75	90	125	165
For current limiting at 350% I_M (40 °C)	W	1043	1355	2448	3257	3277	3600
Permissible rated motor current and starts per hour							
• For normal starting (Class 10)							
- Rated motor current $I_M^{1)}$, starting time 10 s	A	134	162	230	280	356	432
- Starts per hour ²⁾	1/h	20	8	20	14	16	17
- Rated motor current $I_M^{1)3)}$, starting time 20 s	A	134	162	230	280	356	432
- Starts per hour ²⁾	1/h	7	1.4	9	3	5	5
• For heavy starting (Class 15)							
- Rated motor current $I_M^{1)}$, starting time 15 s	A	134	152	230	250	341	402
- Starts per hour ²⁾	1/h	11	8	13	12	11	12
- Rated motor current $I_M^{1)3)}$, starting time 30 s	A	134	152	230	250	341	402
- Starts per hour ²⁾	1/h	1.2	1.7	5	2	1.5	2
• For heavy starting (Class 20)							
- Rated motor current $I_M^{1)}$, starting time 20 s	A	124	142	230	230	311	372
- Starts per hour ²⁾	1/h	12	9	9	10	10	10
- Rated motor current $I_M^{1)3)}$, starting time 40 s	A	124	142	230	230	311	372
- Starts per hour ⁴⁾	1/h	3	3	1	1	0.1	1

- 1) Current limit on soft starter set to 350 % I_M .
- 2) For intermittent duty S4 with ON period = 70 %, $T_u = 40$ °C, stand-alone installation vertical. The quoted operating frequencies do not apply for automatic mode.
- 3) Maximum adjustable rated motor current I_M , dependent on CLASS setting.
- 4) For intermittent duty S4 with ON period = 30 %, $T_u = 40$ °C, stand-alone installation vertical. The quoted operating frequencies do not apply for automatic mode.

3RW Soft Starters

3RW40 for standard applications

Soft starters	Type		3RW40 5.	3RW40 7.
Conductor cross-sections				
Screw terminals	Main conductors:			
With box terminal			3RT19 55-4G (55 kW)	3RT19 66-4G
Front clamping point connected	<ul style="list-style-type: none"> Finely stranded with end sleeve Finely stranded without end sleeve Stranded Ribbon cable conductors (number x width x thickness) AWG conductors, solid or stranded 	mm ² mm ² mm ² mm AWG	16 ... 70 16 ... 70 16 ... 70 Min. 3 x 9 x 0.8, Max. 6 x 15.5 x 0.8 6 ... 2/0	70 ... 240 70 ... 240 95 ... 300 Min. 6 x 9 x 0.8 Max. 20 x 24 x 0.5 3/0 ... 600 kcmil
				
Rear clamping point connected	<ul style="list-style-type: none"> Finely stranded with end sleeve Finely stranded without end sleeve Stranded Ribbon cable conductors (number x width x thickness) AWG conductors, solid or stranded 	mm ² mm ² mm ² mm AWG	16 ... 70 16 ... 70 16 ... 70 Min. 3 x 9 x 0.8, Max. 6 x 15.5 x 0.8 6 ... 2/0	120 ... 185 120 ... 185 120 ... 240 Min. 6 x 9 x 0.8 Max. 20 x 24 x 0.5 250 ... 500 kcmil
				
Both clamping points connected	<ul style="list-style-type: none"> Finely stranded with end sleeve Finely stranded without end sleeve Stranded Ribbon cable conductors (number x width x thickness) AWG conductors, solid or stranded Terminal screws - Tightening torque 	mm ² mm ² mm ² mm AWG	Max. 1 x 50, 1 x 70 Max. 1 x 50, 1 x 70 Max. 2 x 70 Max. 2 x (6 x 15.5 x 0.8) Max. 2 x 1/0 M10 (hexagon socket, A/F4) 10 ... 12 90 ... 110	Min. 2 x 50; max. 2 x 185 Min. 2 x 50; max. 2 x 185 Max. 2 x 70; max. 2 x 240 Max. 2 x (20 x 24 x 0.5) Min. 2 x 2/0; max. 2 x 500 kcmil M12 (hexagon socket, A/F5) 20 ... 22 180 ... 195
				
Screw terminals	Main conductors:			
With box terminal			3RT19 56-4G	
Front or rear clamping point connected	<ul style="list-style-type: none"> Finely stranded with end sleeve Finely stranded without end sleeve Stranded Ribbon cable conductors (number x width x thickness) AWG conductors, solid or stranded 	mm ² mm ² mm ² mm AWG	16 ... 120 16 ... 120 16 ... 120 Min. 3 x 9 x 0.8 Max. 6 x 15.5 x 0.8 6 ... 250 kcmil	
 				
Both clamping points connected	<ul style="list-style-type: none"> Finely stranded with end sleeve Finely stranded without end sleeve Stranded Ribbon cable conductors (number x width x thickness) AWG conductors, solid or stranded 	mm ² mm ² mm ² mm AWG	Max. 1 x 95, 1 x 120 Max. 1 x 95, 1 x 120 Max. 2 x 120 Max. 2 x (10 x 15.5 x 0.8) Max. 2 x 3/0	
				
Screw terminals	Main conductors:			
	<u>Without box terminal/rail connection</u>			
	<ul style="list-style-type: none"> Finely stranded with cable lug Stranded with cable lug AWG conductors, solid or stranded Connecting bar (max. width) Terminal screws - Tightening torque 	mm ² mm ² AWG mm Nm lb.in	16 ... 95 ¹⁾ 25 ... 120 ¹⁾ 4 ... 250 kcmil 17 M8 x 25 (A/F13) 10 ... 14 89 ... 124	50 ... 240 ²⁾ 70 ... 240 ²⁾ 2/0 ... 500 kcmil 25 M10 x 30 (A/F17) 14 ... 24 124 ... 210

1) When connecting cable lugs to DIN 46235 use 3RT19 56-4EA1 terminal cover for conductor cross-sections from 95 mm² to ensure phase spacing.

2) When connecting cable lugs to DIN 46234, the 3RT19 66-4EA1 terminal cover must be used for conductor cross-sections of 240 mm² and more as well as DIN 46235 for conductor cross-sections of 185 mm² and more to keep the phase clearance.

Soft starters	Type		3RW40 ..
Conductor cross-sections			
Auxiliary conductors (1 or 2 conductors can be connected):			
	Screw terminals		
	<ul style="list-style-type: none"> Solid Finely stranded with end sleeve AWG cables - Solid or stranded - Finely stranded with end sleeve Terminal screws - Tightening torque 	mm ² mm ² AWG AWG Nm lb.in	2 x 0.5 ... 2.5 2 x 0.5 ... 1.5 2 x 20 ... 14 2 x 20 ... 16 0.7 ... 0.9 7 ... 8
	Spring-loaded terminals		
	<ul style="list-style-type: none"> Solid Finely stranded with end sleeve AWG conductors, solid or stranded 	mm ² mm ² AWG	2 x 0.25 ... 2.5 2 x 0.25 ... 1.5 2 x 24 ... 14

	Standard	Parameters
Electromagnetic compatibility according to EN 60947-4-2		
<i>EMC interference immunity</i>		
Electrostatic discharge (ESD)	EN 61000-4-2	±4 kV contact discharge, ±8 kV air discharge
Electromagnetic RF fields	EN 61000-4-3	Frequency range: 80 ... 1000 MHz with 80 % at 1 kHz Degree of severity 3: 10 V/m
Conducted RF interference	EN 61000-4-6	Frequency range: 150 kHz ... 80 MHz with 80 % at 1 kHz Interference 10 V
RF voltages and RF currents on conductors		
Burst	EN 61000-4-4	±2 kV/5 kHz
Surge	EN 61000-4-5	±1 kV line to line
<i>EMC interference emission</i>		
EMC interference field strength	EN 55011	Limit value of Class A at 30 ... 1000 MHz
Radio interference voltage	EN 55011	Limit value of Class A at 0.15 ... 30 MHz
<i>Is an RI suppression filter necessary?</i>		
Degree of noise suppression A (industrial applications)	No	

3RW Soft Starters

3RW40 for standard applications

Fuse assignment

The coordination type to which the motor feeder with soft starter is mounted depends on the application-specific requirements. Normally, fuseless mounting (combination of circuit-breaker and soft starter) is sufficient. If type2 coordination is to be fulfilled, semiconductor fuses must be fitted in the motor feeder.

Fuseless version

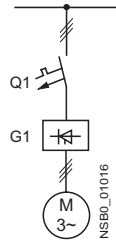

Soft starters		Circuit breakers ¹⁾		
G1 Type	Rated current A	Q1 Type	Q1 Type	Rated current A
		400 V +10 %	575 V +10 %	
Type of coordination 1²⁾: $I_q = 65 \text{ kA at } 400 \text{ V} / I_q = 35 \text{ kA at } 600 \text{ V}$³⁾				
3RW40 55	134	3VL3 720-2DC36	3VL3 720-1DC36	200
3RW40 56	162	3VL3 720-2DC36	3VL3 720-1DC36	200
3RW40 73	230	3VL4 731-2DC36	3VL5 731-3DC36	315
3RW40 74	280	3VL4 731-2DC36	3VL5 731-3DC36	315
3RW40 75	356	3VL4 740-2DC36	3VL5 740-3DC36	400
3RW40 76	432	3VL5 750-2DC36	3VL5 750-3DC36	500

- 1) The rated motor current must be considered when selecting the devices. 3) Except 3RW40 55: $I_q = 35 \text{ kA at } 400 \text{ V} / I_q = 12 \text{ kA at } 600 \text{ V}$.
- 2) The types of coordination are explained in more detail under Fuseless Load Feeders on page 6/48.

Fused version (line protection only)

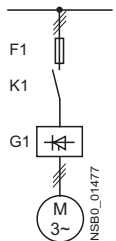

Soft starters		Line protection		Line contactors		
G1 Type	Rated current A	F1 Type	Rated current A	Size	K1 Type 115 V	Type 230 V
Type of coordination 1¹⁾: $I_q = 65 \text{ kA at } 400/600 \text{ V}$						
3RW40 55	134	3NA3 244-6	250	2	3RT10 55-6AF36	3RT10 55-6AP36
3RW40 56	162	3NA3 244-6	250	2	3RT10 56-6AF36	3RT10 56-6AP36
3RW40 73	230	2 x 3NA3 354-6	2 x 355	3	3RT10 65-6AF36	3RT10 65-6AP36
3RW40 74	280	2 x 3NA3 354-6	2 x 355	3	3RT10 66-6AF36	3RT10 66-6AP36
3RW40 75	356	2 x 3NA3 365-6	2 x 500	3	3RT10 75-6AF36	3RT10 75-6AP36
3RW40 76	432	2 x 3NA3 365-6	2 x 500	3	3RT10 76-6AF36	3RT10 76-6AP36

- 1) The types of coordination are explained in more detail under Fuseless Load Feeders on page 6/48.

Fused version with 3NE1 SITOR fuses (semiconductor and line protection)

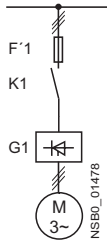

Soft starters		All-range fuses			Line contactors	
G1 Type	Rated current A	F'1 Type	Rated current A	Size	K1 Type 115 V	(optional) Type 230 V
Type of coordination 2¹⁾: I_q = 65 kA at 400/600 V						
3RW40 55	134	3NE1 227-2	250	1	3RT10 55-6AF36	3RT10 55-6AP36
3RW40 56	162	3NE1 227-2	250	1	3RT10 56-6AF36	3RT10 56-6AP36
3RW40 73	230	3NE1 331-2	350	2	3RT10 65-6AF36	3RT10 65-6AP36
3RW40 74	280	3NE1 333-2	450	2	3RT10 66-6AF36	3RT10 66-6AP36
3RW40 75	356	3NE1 334-2	500	2	3RT10 75-6AF36	3RT10 75-6AP36
3RW40 76	432	3NE1 435-2	560	3	3RT10 76-6AF36	3RT10 76-6AP36

1) The types of coordination are explained in more detail under Fuseless Load Feeders on page 6/48.

Fused version with 3NE3 SITOR fuses (semiconductor protection by fuse, lead and overload protection by circuit-breaker; alternatively, installation with contactor and overload relay possible)

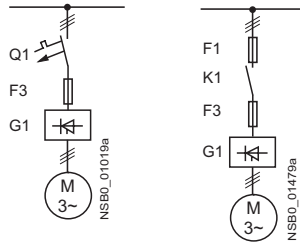

Soft starters		Semiconductor fuses, minimum			Semiconductor fuses, maximum			Line contactors	
G1 Type	Rated current A	F3 Type	Rated current A	Size	F3 Type	Rated current A	Size	K1 Type 115 V	(optional) Type 230 V
Type of coordination 2¹⁾: I_q = 65 kA at 400/600 V									
3RW40 55	134	3NE3 227	250	1	3NE3 335	560	2	3RT10 55-6AF36	3RT10 55-6AP36
3RW40 56	162	3NE3 227	250	1	3NE3 335	560	2	3RT10 56-6AF36	3RT10 56-6AP36
3RW40 73	230	3NE3 232-0B	400	1	3NE3 333	450	2	3RT10 65-6AF36	3RT10 65-6AP36
3RW40 74	280	3NE3 233	450	1	3NE3 336	630	2	3RT10 66-6AF36	3RT10 66-6AP36
3RW40 75	356	3NE3 335	560	2	3NE3 336	630	2	3RT10 75-6AF36	3RT10 75-6AP36
3RW40 76	432	3NE3 337-8	710	2	3NE3 340-8	900	2	3RT10 76-6AF36	3RT10 76-6AP36

Soft starters		Circuit-breakers			Line protection		
G1 Type	Rated current A	Q1 Type	Rated current A	Q1 Type	F1 Type	Rated current A	Size
Type of coordination 2¹⁾: I_q = 65 kA at 400/600 V							
3RW40 55	134	3VL3 720-2DC36	200	3VL3 720-1DC36	3NA3 244-6	250	2
3RW40 56	162	3VL3 720-2DC36	200	3VL3 720-1DC36	3NA3 244-6	250	2
3RW40 73	230	3VL4 731-2DC36	315	3VL5 731-3DC36	2 x 3NA3 354-6	2 x 355	3
3RW40 74	280	3VL4 731-2DC36	315	3VL5 731-3DC36	2 x 3NA3 354-6	2 x 355	3
3RW40 75	356	3VL4 740-2DC36	400	3VL5 740-3DC36	2 x 3NA3 365-6	2 x 500	3
3RW40 76	432	3VL5 750-2DC36	500	3VL5 750-3DC36	2 x 3NA3 365-6	2 x 500	3

1) The types of coordination are explained in more detail under Fuseless Load Feeders on page 6/48.



3RW40 for standard applications

Characteristic curves

Motor protection tripping characteristics for 3RW40
(with symmetry)

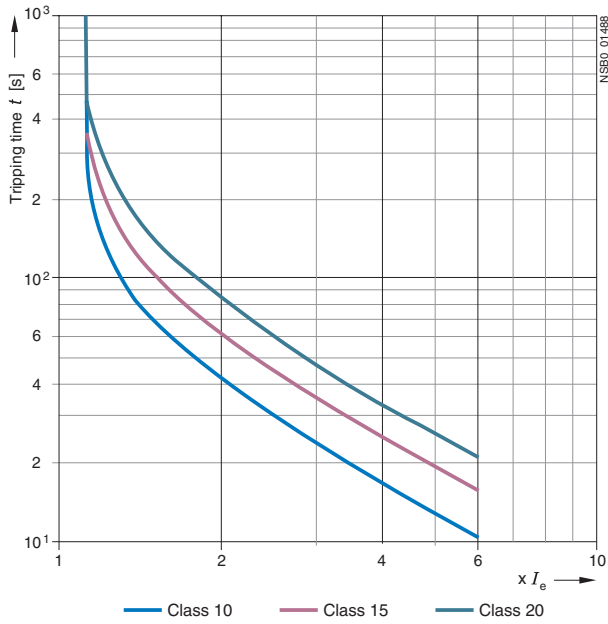

More information

Configuration

The 3RW solid-state soft starters are designed for easy starting conditions. In the event of deviating conditions or increased switching frequency, it may be necessary to choose a larger device. For accurate dimensioning, use the Win-Soft Starter selection and simulation program (Version 2.0 upwards).

If necessary, an overload relay for heavy-starting must be selected where long starting times are involved. PTC sensors are recommended. This also applies for the smooth ramp-down because during the ramp-down time an additional current load-applies in contrast to free ramp-down.

In the motor feeder between the SIRIUS 3RW soft starter and the motor, no capacitive elements are permitted (e.g. no reactive-power compensation equipment). In addition, neither static systems for reactive-power compensation nor dynamic PFC (Power Factor Correction) must be operated in parallel during starting and ramp-down of the soft starter. This is important to prevent faults arising on the compensation equipment and/or the soft starter.

All elements of the main circuit (such as fuses, controls and overload relays) should be dimensioned for direct starting, following the local short-circuit conditions. Fuses, switching devices and overload relays must be ordered separately. Please observe the maximum switching frequencies specified in the technical specifications.

Power electronics circuit diagram

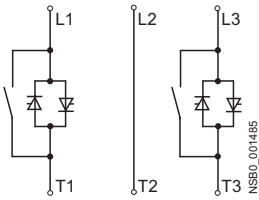

Status graphs

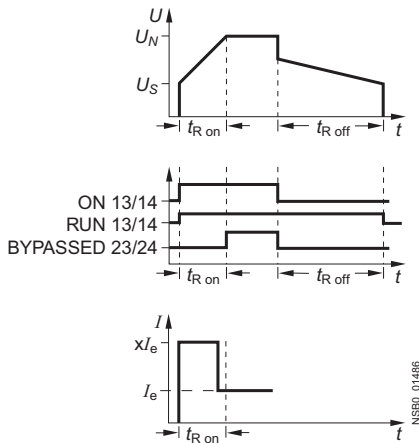

Win-Soft Starter selection and simulation program

With this software, you can simulate and select all Siemens soft starters, taking into account various parameters such as mains properties, motor and load data, and special application requirements.

The software is a valuable tool, which makes complicated, lengthy manual calculations for determining the required soft starters superfluous.

You can order the CD-ROM under the following order number:
Order No. E20001-D1020-P302-V2-7400.

More information can be found on the Internet at
<http://www.siemens.com/softstarter>

3RW44 for High-Feature applications

Overview

In addition to soft starting and soft ramp-down, the solid-state SIRIUS 3RW44 soft starters provide numerous functions for higher-level requirements. They cover a rating range up to 710 kW (at 400 V) in the inline circuit and up to 1200 kW (at 400 V) in the inside-delta circuit.

The SIRIUS 3RW44 soft starters are characterized by a compact design for space-saving and clearly arranged control cabinet layouts. For optimized motor starting and stopping the innovative SIRIUS 3RW44 soft starters are an attractive alternative with considerable savings potential compared to applications with a frequency converter. The new torque control and adjustable current limiting enable the High-Feature soft starters to be used in nearly every conceivable task. They guarantee the reliable avoidance of sudden torque applications and current peaks during motor starting and stopping. This creates savings potential when calculating the size of the switchgear and when servicing the machinery installed. Be it for inline circuits or inside-delta circuits – the SIRIUS 3RW44 soft starter offers savings especially in terms of size and equipment costs.

Combinations of various starting, operating and ramp-down possibilities ensure an optimum adaptation to the application-specific requirements. Operation and commissioning can be carried out with the menu-controlled keypad plus menu-controlled, multi-line graphic display with background lighting. The optimized motor ramp-up and ramp-down can be effected quickly, easily and reliably by means of just a few settings with a previously selected language. Four-key operation and plain-text displays for each menu point guarantee full clarity at every moment of the parameterization and operation.

Applicable standards

- IEC 60947-4-2
- UL/CSA

Function

Equipped with modern, ergonomic user prompting the SIRIUS 3RW44 soft starters can be commissioned quickly and easily using a keypad and a menu-prompted, multi-line display with background lighting. The optimized motor ramp-up and ramp-down can be effected quickly, easily and reliably by means of just a few settings with a selectable language. Four-key operation and plain-text displays for each menu point guarantee full clarity at every moment of the parameterization and operation. During operation and when control voltage is applied, the front panel continuously presents measured values and operating values as well as warnings and alarm indications. An external display and operator module can be connected by means of a connecting cable to the soft starter, thus enabling active indications and the like to be read directly from the control cabinet door.

The SIRIUS 3RW44 soft starters are equipped with optimum functionality. An integral bypass contact system reduces the power loss of the soft starter during operation. This reliably prevents heating of the switchgear environment. The SIRIUS 3RW44 soft starters have internal intrinsic device protection. This prevents thermal overloading of the power section's thyristors, e.g. due to unacceptably high closing operations.

Wiring work for installing an additional motor overload relay is no longer needed as the SIRIUS 3RW44 soft starters perform this function too. In addition they offer adjustable trip classes and a thermistor motor protection function. As an option the thyristors can also be protected by SITOR semi-conductor fuses from short-circuiting. And even inrush current peaks are reliably avoided thanks to adjustable current limiting.

As a further option the SIRIUS 3RW44 soft starters can be upgraded with a PROFIBUS DP module. Thanks to their communication capability and their programmable control inputs and relay outputs the SIRIUS 3RW44 soft starters can be very easily and quickly integrated in higher-level controllers.

In addition a creep speed function is available for positioning and setting jobs. With this function the motor can be controlled in both directions of rotation with reduced torque and an adjustable, low speed.

On the other hand the SIRIUS 3RW44 soft starters offer a new, combined DC braking function for the fast stopping of driving loads.

Highlights

- Soft starting with breakaway pulse, torque control or voltage ramp, adjustable torque or current limiting as well as any combination of these, depending on load type
- Integrated bypass contact system to minimize dissipated power
- Various setting options for the starting parameters such as starting torque, starting voltage, ramp-up and ramp-down time, and much more in three separate parameter sets
- Start-up detection
- Inside-delta circuit for savings in terms of size and equipment costs
- Various ramp-down modes selectable: free ramp-down, torque-controlled pump stopping, combined DC braking
- Solid-state motor overload and intrinsic device protection
- Thermistor motor protection
- Keypad with a menu-controlled, multi-line, graphic display with background lighting
- Interface for communication with the PC for more accurate setting of the parameters as well as for control and monitoring (start of delivery of the software: end of 2005)
- Simple adaptation to the motor feeder
- Simple mounting and commissioning
- Display of operating states and fault signals
- Connection to PROFIBUS with optional PROFIBUS DP module (start of delivery: 2006).
- External display and operator module (start of delivery: 2006).
- System voltages from 200 to 690 V, 50 to 60 Hz
- Applicable up to 60 °C (derating from 40 °C)

Technical specifications

Type	Terminal		3RW44 ...-BC3.	3RW44 ...-BC4.
Control electronics				
Rated values				
Rated control supply voltage	A1/A2/PE	V	115 AC	230 AC
• Tolerance		%	-15/+10	-15/+10
Rated control supply current STANDBY		mA	30	20
Rated control supply current ON				
• 3RW442.		mA	300	170
• 3RW443.		mA	500	250
• 3RW444.		mA	750	400
Maximum current (pickup bypass)				
• 3RW442.		mA	1000	500
• 3RW443.		mA	2500	1250
• 3RW444.		mA	6000	3000
Rated frequency		Hz	50 ... 60	50 ... 60
• Tolerance		%	±10	±10

Type	Terminal		3RW44 ..	Factory presetting
Control electronics				
Control inputs				
Input 1	IN1		Approx. 10 per input to DIN 19240 Internal voltage: 24 V DC from internal supply through terminal L+ to IN1 ... IN4. Maximum load at L+ Approx. 55 mA External voltage: DC external voltage (according to DIN 19240) through terminals L- and IN1 ... IN4 (min. 12 V DC, max. 30 V DC)	Start motor right parameter set 1 No action No action Trip reset
Input 2	IN2			
Input 3	IN3			
Input 4	IN4			
Supply	L+/L-			
• Rated operational current	L+	mA		
• Rated operational voltage	L-			
Thermistor motor protection input				
Input	T1/T2		PTC type A or Thermoclick	Deactivated
Relay outputs (floating auxiliary contacts)				
Output 1	13/14			ON period
Output 2	23/24			No action
Output 3	33/34			No action
Output 4	95/96/98			Group fault
Switching capacity of the relay outputs				
230 V/AC-15		A	3 at 240 V	
24 V/DC-13		A	1 at 24 V	
Protection against overvoltages			Protection by means of varistor through relay contact	
Short-circuit protection			4 A gL/gG operational class; 6 A quick (fuse is not included in scope of supply)	
Protective functions				
Motor protection functions				
Trips in the event of			Thermal overloading of the motor	10
Trip class to IEC 60947-4-1		Class	5/10/15/20/30	
Phase loss sensitivity		%	> 40	
Overload warning			Yes	Manual Manual 2
Reset and recovery			Manual/Automatic	
Reset option after tripping			Manual/Automatic	
Recovery time		min.	2 ... 30	
Device protection functions				
Trips in the event of			Thermal overloading of the thyristors	Manual
Reset option after tripping			Manual/Automatic	
Recovery time		min.	0.5	

3RW Soft Starters

3RW44 for High-Feature applications

Type	3RW44 ..			Factory presetting
Control times and parameters				
Control times				
Closing delay (with connected control voltage)	ms	< 50		
Closing delay (automatic mode)	ms	< 4000		
Recovery time (closing command in active ramp-down)	ms	< 100		
Mains failure bridging time				
Control supply voltage	ms	100		
Mains failure response time				
Load current circuit	ms	100		
Reclosing lockout after overload trip				
Motor protection trip	min.	1 ... 30		1
Device protection trip	s	30		
Setting options for starting				
Voltage ramp for starting voltage	%	20 ... 100		40
Torque control for starting torque	%	10 ... 100		50
Torque control for limit torque	%	20 ... 200		150
Starting time	s	0 ... 360		20
Maximum starting time	s	1 ... 1000		Deactivated
Current limit value	%	125 ... 550		450
Breakaway voltage	%	40 ... 100		80
Breakaway time	s	0 ... 2		Deactivated
Motor heat output	%	0 ... 100		0
Creep mode Left/Right running				
Speed factor as function of rated speed ($n = n_{rated}/factor$)		3 ... 21		7
Creep torque (reference variable depends on the motor used but is always smaller than the rated torque of the motor)	%	20 ... 100		50
Setting options for ramp-down				
Torque control for stopping torque	%	10 ... 100		40
Ramp-down time	s	0 ... 360		10
Combined braking	%	20 ... 100		50
DC braking	%	20 ... 100		50
Operating indications				
		Test voltage		
		Test mains phases		
		Ready to start		
		Start active		
		Motor running		
		Ramp-down active		
Warnings/error signals				
		Mains voltage missing		
		Wrong start condition		
		Phase failure		
		• L1		
		• L2		
		• L3		
		Missing load phase		
		• T1		
		• T2		
		• T3		
		Failure		
		• Contact element 1 (thyristor)		
		• Contact element 2 (thyristor)		
		• Contact element 3 (thyristor)		
		Flash memory faulty		
		Supply voltage		
		• Below 75 %		
		• Below 85 %		
		• Over 110 %		
		Current unbalance exceeded		
		Thermal motor model overload		
		Prewarning limit exceeded		
		• Motor heating		
		• Time-related trip reserve		
		Bypass elements defective		
		Mains overvoltage		
		Current range exceeded		
		Motor blocking – shutdown		
		Current limit exceeded		
		Power section overheated		
		Power section overtemperature		
		Temperature sensor		
		- Overload		
		- Open-circuit		
		- Short-circuit		
		Ground fault detected		
		Ground fault shutdown		
		Connection abort in manual mode		

Type	3RW44 ..	Factory presetting
Control times and parameters		
Control inputs Input 1 Input 2 Input 3 Input 4 Parameterizing options for control inputs 1 ... 4	No action Local manual mode Creep speed Trip reset Motor right parameter set 1 Motor left parameter set 1 ¹⁾ Motor right parameter set 2 Motor left parameter set 2 ¹⁾ Motor right parameter set 3 Motor left parameter set 3 ¹⁾	Motor right parameter set 1 No action No action Trip reset
Relay outputs Output 1 Output 2 Output 3 Output 4 Parameterizing options for relay outputs 1 ... 3	No action PAA output 1 PAA output 2 Input 1 Input 2 Input 3 Input 4 Starting Operation/Bypass Ramp-down ON period Command motor on DC braking contactor Group warning Group fault Device error Power on Ready to start	ON period No action No action Group fault
Motor temperature sensor	Deactivated Thermoclick PTC type A	Deactivated

1) Parameter motor left possible only in conjunction with creep mode.

3RW Soft Starters

3RW44 for High-Feature applications

Type		3RW44 ..-BC.4	3RW44 ..-BC.5	3RW44 ..-BC.6
Power electronics				
Rated operational voltage for inline circuit	V	200 ... 460 AC	400 ... 600 AC	400 ... 690 AC
Tolerance	%	-15/+10	-15/+10	-15/+10
Rated operational voltage for inside-delta circuit	V	200 ... 400 AC	400 ... 600 AC	400 ... 600 AC
Tolerance	%	-15/+10	-15/+10	-15/+10
Rated frequency	Hz	50 ... 60		
Tolerance	%	±10		
Continuous operation at 40 °C (% of I_e)	%	115		
Minimum load (% of I_e)	%	20		
Maximum conductor length between soft starter and motor	m	200		
Permissible installation height	m	2000 (derating from 1000); higher on request		
Permissible mounting position				
Permissible ambient temperature		0 ... +60; (derating from +40)		
Operation	°C			
Storage	°C	-25 ... +80		
Degree of protection		IP00		

Type		3RW44 22	3RW44 23	3RW44 24	3RW44 25	3RW44 26	3RW44 27
Power electronics							
Rated operational current I_e		29	36	47	57	77	93
Load rating with rated operational current I_e							
• According to IEC and UL/CSA for individual mounting, at 40/50/60 °C, AC-53a	A	29/26/23	36/32/29	47/42/37	57/51/45	77/68/59	93/82/72
Smallest adjustable rated motor current I_M	A	5	7	9	11	15	18
For the motor overload protection							
Power loss							
• In operation after completed ramp-up with uninterrupted rated operational current (40 °C) approx.	W	8	10	32	36	45	55
• During starting with current limit set to 350 % I_M (40 °C)	W	400	470	600	725	940	1160
Permissible rated motor current and starts per hour							
• Normal starting (Class 5)							
- Rated motor current $I_M^{(1)}$, starting time 5 s	A	29	36	47	57	77	93
- Starts per hour ⁽²⁾	1/h	41	34	41	41	41	41
- Rated motor current $I_M^{(1)(3)}$, starting time 10 s	A	29	36	47	57	77	93
- Starts per hour ⁽²⁾	1/h	20	15	20	20	20	20
• Normal starting (Class 10)							
- Rated motor current $I_M^{(1)}$, starting time 10 s	A	29	36	47	57	77	93
- Starts per hour ⁽²⁾	1/h	20	15	20	20	20	20
- Rated motor current $I_M^{(1)(3)}$, starting time 20 s	A	29	36	47	57	77	93
- Starts per hour ⁽²⁾	1/h	10	6	10	10	8	8
• Normal starting (Class 15)							
- Rated motor current $I_M^{(1)}$, starting time 15 s	A	29	36	47	57	77	93
- Starts per hour ⁽²⁾	1/h	13	9	13	13	13	13
- Rated motor current $I_M^{(1)(3)}$, starting time 30 s	A	29	36	47	57	77	93
- Starts per hour ⁽²⁾	1/h	6	4	6	6	6	6
• For heavy starting (Class 20)							
- Rated motor current $I_M^{(1)}$, starting time 20 s	A	29	36	47	57	73	88
- Starts per hour ⁽²⁾	1/h	10	6	10	10	10	10
- Rated motor current $I_M^{(1)(3)}$, starting time 40 s	A	29	36	47	57	73	88
- Starts per hour ⁽²⁾	1/h	4	2	4	5	1.8	0.8
• For very heavy starting (Class 30)							
- Rated motor current $I_M^{(1)}$, starting time 30 s	A	29	36	44	57	65	77
- Starts per hour ⁽²⁾	1/h	6	4	6	6	6	6
- Rated motor current $I_M^{(1)(3)}$, starting time 60 s	A	29	36	44	57	65	77
- Starts per hour ⁽²⁾	1/h	1.8	0.8	3.3	1.5	2	1

1) Current limit on soft starter set to 350 % I_M .

2) For intermittent duty S4 with ON period = 70 %, $T_u = 40$ °C, stand-alone installation vertical. The quoted operating frequencies do not apply for automatic mode.

3) Maximum adjustable rated motor current $I_M^{(3)}$, dependent on CLASS setting.

Type		3RW44 34	3RW44 35	3RW44 36
Power electronics				
Rated operational current I_e		113	134	162
Load rating with rated operational current I_e				
• According to IEC and UL/CSA for individual mounting, at 40/50/60 °C, AC-53a	A	113/100/88	134/117/100	162/145/125
Smallest adjustable rated motor current I_M	A	22	26	32
For the motor overload protection				
Power loss				
• In operation after completed ramp-up with uninterrupted rated operational current (40 °C) approx.	W	64	76	95
• During starting with current limit set to 350 % I_M (40 °C)	W	1350	1700	2460
Permissible rated motor current and starts per hour				
• Normal starting (Class 5)				
- Rated motor current $I_M^{(1)}$, starting time 5 s	A	113	134	162
- Starts per hour ⁽²⁾	1/h	41	39	41
- Rated motor current $I_M^{(1)(3)}$, starting time 10 s	A	113	134	162
- Starts per hour ⁽²⁾	1/h	20	15	20
• Normal starting (Class 10)				
- Rated motor current $I_M^{(1)}$, starting time 10 s	A	113	134	162
- Starts per hour ⁽²⁾	1/h	20	15	20
- Rated motor current $I_M^{(1)(3)}$, starting time 20 s	A	113	134	162
- Starts per hour ⁽²⁾	1/h	9	6	7
• Normal starting (Class 15)				
- Rated motor current $I_M^{(1)}$, starting time 15 s	A	113	134	162
- Starts per hour ⁽²⁾	1/h	13	9	12
- Rated motor current $I_M^{(1)(3)}$, starting time 30 s	A	113	134	162
- Starts per hour ⁽²⁾	1/h	6	6	6
• For heavy starting (Class 20)				
- Rated motor current $I_M^{(1)}$, starting time 20 s	A	106	125	147
- Starts per hour ⁽²⁾	1/h	9	9	10
- Rated motor current $I_M^{(1)(3)}$, starting time 40 s	A	106	125	147
- Starts per hour ⁽²⁾	1/h	1.5	2	0.5
• For very heavy starting (Class 30)				
- Rated motor current $I_M^{(1)}$, starting time 30 s	A	91	110	120
- Starts per hour ⁽²⁾	1/h	6	6	6
- Rated motor current $I_M^{(1)(3)}$, starting time 60 s	A	91	110	120
- Starts per hour ⁽²⁾	1/h	2	2	0.5

1) Current limit on soft starter set to 350 % I_M .

2) For intermittent duty S4 with ON period = 70 %, $T_u = 40$ °C, stand-alone installation vertical. The quoted operating frequencies do not apply for automatic mode.

3) Maximum adjustable rated motor current I_M , dependent on CLASS setting.

3RW Soft Starters







3RW44 for High-Feature applications

Type		3RW44 43	3RW44 44	3RW44 45	3RW44 46	3RW44 47
Power electronics						
Rated operational current I_e		203	250	313	356	432
Load rating with rated operational current I_e						
<ul style="list-style-type: none"> According to IEC and UL/CSA for individual mounting, at 40/50/60 °C, AC-53a 	A	203/180/156	250/215/185	313/280/250	356/315/280	432/385/335
Smallest adjustable rated motor current I_M	A	40	50	62	71	86
For the motor overload protection						
Power loss						
<ul style="list-style-type: none"> In operation after completed ramp-up with uninterrupted rated operational current (40 °C) approx. 	W	89	110	145	174	232
<ul style="list-style-type: none"> During starting with current limit set to 350 % I_M (40 °C) 	W	3350	4000	4470	5350	5860
Permissible rated motor current and starts per hour						
• Normal starting (Class 5)						
- Rated motor current $I_M^{(1)}$, starting time 5 s	A	203	250	313	356	432
- Starts per hour ⁽²⁾	1/h	41	40	41	41	39
- Rated motor current $I_M^{(1)(3)}$, starting time 10 s	A	203	250	313	356	432
- Starts per hour ⁽²⁾	1/h	20	20	20	17	16
• Normal starting (Class 10)						
- Rated motor current $I_M^{(1)}$, starting time 10 s	A	203	250	313	356	432
- Starts per hour ⁽²⁾	1/h	20	20	20	17	16
- Rated motor current $I_M^{(1)(3)}$, starting time 20 s	A	203	250	313	356	432
- Starts per hour ⁽²⁾	1/h	10	8	8	4	5
• Normal starting (Class 15)						
- Rated motor current $I_M^{(1)}$, starting time 15 s	A	203	240	313	325	402
- Starts per hour ⁽²⁾	1/h	13	11	13	13	11
- Rated motor current $I_M^{(1)(3)}$, starting time 30 s	A	203	240	313	325	402
- Starts per hour ⁽²⁾	1/h	6	6	6	6	6
• For heavy starting (Class 20)						
- Rated motor current $I_M^{(1)}$, starting time 20 s	A	195	215	275	285	356
- Starts per hour ⁽²⁾	1/h	10	10	10	10	10
- Rated motor current $I_M^{(1)(3)}$, starting time 40 s	A	195	215	275	285	356
- Starts per hour ⁽²⁾	1/h	4	1.5	3	3	1.8
• For very heavy starting (Class 30)						
- Rated motor current $I_M^{(1)}$, starting time 30 s	A	162	180	220	240	285
- Starts per hour ⁽²⁾	1/h	6	6	6	6	6
- Rated motor current $I_M^{(1)(3)}$, starting time 60 s	A	162	180	220	240	285
- Starts per hour ⁽²⁾	1/h	4.3	1.8	3	2	1.6

1) Current limit on soft starter set to 350 % I_M .

2) For intermittent duty S4 with ON period = 70 %, $T_u = 40$ °C, stand-alone installation vertical. The quoted operating frequencies do not apply for automatic mode.

3) Maximum adjustable rated motor current I_M , dependent on CLASS setting.

Type	3RW44 2.		3RW44 3., 3RW44 4.	
Conductor cross-sections				
Screw terminals	Main conductors:			
With box terminal			3RT19 55-4G (55 kW)	3RT19 66-4G
Front clamping point connected	<ul style="list-style-type: none"> Finely stranded with end sleeve Finely stranded without end sleeve Stranded Ribbon cable conductors (number x width x thickness) AWG conductors, solid or stranded 	mm ² mm ² mm ² mm AWG	16 ... 70 16 ... 70 16 ... 70 Min. 3 x 9 x 0.8, Max. 6 x 15.5 x 0.8 6 ... 2/0	70 ... 240 70 ... 240 95 ... 300 Min. 6 x 9 x 0.8 Max. 20 x 24 x 0.5 3/0 ... 600 kcmil
				
Rear clamping point connected	<ul style="list-style-type: none"> Finely stranded with end sleeve Finely stranded without end sleeve Stranded Ribbon cable conductors (number x width x thickness) AWG conductors, solid or stranded 	mm ² mm ² mm ² mm AWG	16 ... 70 16 ... 70 16 ... 70 Min. 3 x 9 x 0.8, Max. 6 x 15.5 x 0.8 6 ... 2/0	120 ... 185 120 ... 185 120 ... 240 Min. 6 x 9 x 0.8 Max. 20 x 24 x 0.5 250 ... 500 kcmil
				
Both clamping points connected	<ul style="list-style-type: none"> Finely stranded with end sleeve Finely stranded without end sleeve Stranded Ribbon cable conductors (number x width x thickness) AWG conductors, solid or stranded Terminal screws - Tightening torque 	mm ² mm ² mm ² mm AWG	Max. 1 x 50, 1 x 70 Max. 1 x 50, 1 x 70 Max. 2 x 70 Max. 2 x (6 x 15.5 x 0.8) Max. 2 x 1/0 M10 (hexagon socket, A/F4) 10 ... 12 90 ... 110	Min. 2 x 50; max. 2 x 185 Min. 2 x 50; max. 2 x 185 Max. 2 x 70; max. 2 x 240 Max. 2 x (20 x 24 x 0.5) Min. 2 x 2/0; max. 2 x 500 kcmil M12 (hexagon socket, A/F5) 20 ... 22 180 ... 195
				
Screw terminals	Main conductors:			
With box terminal			3RT19 56-4G	
Front or rear clamping point connected	<ul style="list-style-type: none"> Finely stranded with end sleeve Finely stranded without end sleeve Stranded Ribbon cable conductors (number x width x thickness) AWG conductors, solid or stranded 	mm ² mm ² mm ² mm AWG	16 ... 120 16 ... 120 16 ... 120 Min. 3 x 9 x 0.8 Max. 6 x 15.5 x 0.8 6 ... 250 kcmil	
 				
Both clamping points connected	<ul style="list-style-type: none"> Finely stranded with end sleeve Finely stranded without end sleeve Stranded Ribbon cable conductors (number x width x thickness) AWG conductors, solid or stranded 	mm ² mm ² mm ² mm AWG	Max. 1 x 95, 1 x 120 Max. 1 x 95, 1 x 120 Max. 2 x 120 Max. 2 x (10 x 15.5 x 0.8) Max. 2 x 3/0	
				
Screw terminals	Main conductors:			
	<u>Without box terminal/rail connection</u>			
	<ul style="list-style-type: none"> Finely stranded with cable lug Stranded with cable lug AWG conductors, solid or stranded Connecting bar (max. width) Terminal screws - Tightening torque 	mm ² mm ² AWG mm Nm lb.in	16 ... 95 ¹⁾ 25 ... 120 ¹⁾ 4 ... 250 kcmil 17 M8 x 25 (A/F13) 10 ... 14 89 ... 124	50 ... 240 ²⁾ 70 ... 240 ²⁾ 2/0 ... 500 kcmil 25 M10 x 30 (A/F17) 14 ... 24 124 ... 210

1) When connecting cable lugs to DIN 46235 use 3RT19 56-4EA1 terminal cover for conductor cross-sections from 95 mm² to ensure phase spacing.

2) When connecting cable lugs to DIN 46234, the 3RT19 66-4EA1 terminal cover must be used for conductor cross-sections of 240 mm² and more as well as DIN 46235 for conductor cross-sections of 185 mm² and more to keep the phase clearance.

Soft starters	Type	3RW44 ..	
Conductor cross-sections			
Auxiliary conductors (1 or 2 conductors can be connected):			
Screw terminals			
<ul style="list-style-type: none"> Solid Finely stranded with end sleeve 	mm ² mm ²	2 x 0.5 ... 2.5 2 x 0.5 ... 1.5	
<ul style="list-style-type: none"> AWG cables - Solid or stranded - Finely stranded with end sleeve 	AWG AWG	2 x 20 ... 14 2 x 20 ... 16	
<ul style="list-style-type: none"> Terminal screws - Tightening torque 	Nm lb.in	0.7 ... 0.9 7 ... 8	
Spring-loaded terminals			
<ul style="list-style-type: none"> Solid Finely stranded with end sleeve AWG conductors, solid or stranded 	mm ² mm ² AWG	2 x 0.25 ... 2.5 2 x 0.25 ... 1.5 2 x 24 ... 14	



3RW Soft Starters

3RW44 for High-Feature applications

	Standard	Parameters
Electromagnetic compatibility according to EN 60947-4-2		
<i>EMC interference immunity</i>		
Electrostatic discharge (ESD)	EN 61000-4-2	±4 kV contact discharge, ±8 kV air discharge
Electromagnetic RF fields	EN 61000-4-3	Frequency range: 80 ... 1000 MHz with 80 % at 1 kHz Degree of severity 3, 10 V/m
Conducted RF interference	EN 61000-4-6	Frequency range: 150 kHz ... 80 MHz with 80 % at 1 kHz Interference 10 V
RF voltages and RF currents on conductors Burst Surge	EN 61000-4-4 EN 61000-4-5	±2 kV/5 kHz ±1 kV line to line ±2 kV line to ground
<i>EMC interference emission</i>		
EMC interference field strength	EN 55011	Limit value of Class A at 30 ... 1000 MHz
Radio interference voltage	EN 55011	Limit value of Class A at 0.15 ... 30 MHz
<i>Is an RI suppression filter necessary?</i>		
Degree of noise suppression A (industrial applications)	No	

Fuse assignment

The coordination type to which the motor feeder with soft starter is mounted depends on the application-specific requirements. Normally, fuseless mounting (combination of motor starter protector and soft starter) is sufficient. If type 2 coordination is to be fulfilled, semiconductor fuses must be fitted in the motor feeder.

Inline circuit fuseless version

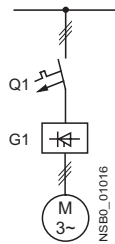

Soft starters		Motor starter protectors/ circuit-breakers ¹⁾	
G1 Type	Rated current A	Q1 Type	Rated current A
Type of coordination 1²⁾: 3RW44 22 ... 3RW44 27: $I_q = 32$ kA; 3RW44 34 and 3RW44 35: $I_q = 16$ kA; 3RW44 36 ... 3RW44 47: $I_q = 65$ kA			
3RW44 22	29	3RV10 42-4HA10	50
3RW44 23	36	3RV10 42-4JA10	63
3RW44 24	47	3RV10 42-4KA10	75
3RW44 25	57	3RV10 42-4LA10	90
3RW44 26	77	3RV10 42-4MA10	100
3RW44 27	93	3RV10 42-4MA10	100
3RW44 34	113	3VL17 16-2DD36	160
3RW44 35	134	3VL17 16-2DD36	160
3RW44 36	162	3VL37 25-2DC36	250
3RW44 43	203	3VL47 31-3DC36	315
3RW44 44	250	3VL47 31-3DC36	315
3RW44 45	313	3VL47 40-3DC36	400
3RW44 46	356	3VL47 40-3DC36	400
3RW44 47	432	3VL57 50-3DC36	500

1) The rated motor current must be considered when selecting the devices.

2) The types of coordination are explained in more detail under Fuseless Load Feeders on page 6/48.

Inline circuit fused version (line protection only)

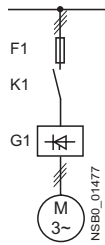

Soft starters G1 Type	Rated current A	Line protection			Line contactors up to 400 V	Braking contactors ¹⁾²⁾	
		690 V +5 % F1 Type	Rated current A	Size	(optional) K1 Type	(for typical circuit see page 6/46) K2 Type	K3 Type
Type of coordination 1³⁾: I_q = 65 kA							
3RW44 22	29	3NA3 820-6	50	00	3RT10 34	3RT15 26	–
3RW44 23	36	3NA3 822-6	63	00	3RT10 35	3RT15 26	–
3RW44 24	47	3NA3 824-6	80	00	3RT10 36	3RT15 35	–
3RW44 25	57	3NA3 830-6	100	00	3RT10 44	3RT15 35	–
3RW44 26	77	3NA3 132-6	125	1	3RT10 45	3RT10 24	3RT10 35
3RW44 27	93	3NA3 136-6	160	1	3RT10 46	3RT10 25	3RT10 36
3RW44 34	113	3NA3 244-6	250	2	3RT10 54	3RT10 34	3RT10 44
3RW44 35	134	3NA3 244-6	250	2	3RT10 55	3RT10 36	3RT10 45
3RW44 36	162	3NA3 365-6	500	3	3RT10 56	3RT10 44	3RT10 45
3RW44 43	203	2 x 3NA3 354-6	2 x 355	3	3RT10 64	3RT10 44	3RT10 54
3RW44 44	250	2 x 3NA3 354-6	2 x 355	3	3RT10 65	3RT10 44	3RT10 55
3RW44 45	313	2 x 3NA3 365-6	2 x 500	3	3RT10 75	3RT10 54	3RT10 56
3RW44 46	356	2 x 3NA3 365-6	2 x 500	3	3RT10 75	3RT10 54	3RT10 56
3RW44 47	432	2 x 3NA3 365-6	2 x 500	3	3RT10 76	3RT10 55	3RT10 64

1) If the ramp-down function "Combined braking" is selected, no braking contactor is required.
 If the ramp-down function "DC braking" is selected, a braking contactor must be used in addition (see table for type).
 For applications with large centrifugal masses ($J_{Load} > J_{Motor}$) we recommend the function "DC braking".

2) Additional auxiliary relay K4:
 LZX:RT4A4T30
 (3RW44 soft starter with rated control supply voltage 230 V AC),
 LZX:RT4A4S15
 (3RW44 soft starter with rated control supply voltage 115 V AC).

3) The types of coordination are explained in more detail under Fuseless Load Feeders on page 6/48.

3RW Soft Starters

3RW44 for High-Feature applications

Inline circuit fused version with 3NE1 SITOR all-range fuse (semiconductor and line protection)

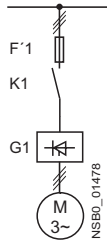

Soft starters		All-range fuses			Line contactors up to 400 V (optional)	Braking contactors ¹⁾²⁾ (for typical circuit see page 6/46)		
G1 Type	Rated current A	F'1 Type	Rated current A	Voltage V	Size	K1 Type	K2 Type	K3 Type
Type of coordination 2³⁾: $I_q = 65 \text{ kA}$								
3RW44 22	29	3NE1 020-2	80	690 +5 %	00	3RT10 34	3RT15 26	–
3RW44 23	36	3NE1 020-2	80	690 +5 %	00	3RT10 35	3RT15 26	–
3RW44 24	47	3NE1 021-2	100	690 +5 %	00	3RT10 36	3RT15 35	–
3RW44 25	57	3NE1 022-2	125	690 +5 %	00	3RT10 44	3RT15 35	–
3RW44 26	77	3NE1 022-2	125	690 +5 %	00	3RT10 45	3RT10 24	3RT10 35
3RW44 27	93	3NE1 024-2	160	690 +5 %	1	3RT10 46	3RT10 25	3RT10 36
3RW44 34	113	3NE1 225-2	200	690 +5 %	1	3RT10 54	3RT10 34	3RT10 44
3RW44 35	134	3NE1 227-2	250	690 +5 %	1	3RT10 55	3RT10 36	3RT10 45
3RW44 36	162	3NE1 227-2	250	690 +5 %	1	3RT10 56	3RT10 44	3RT10 45
3RW44 43	203	3NE1 230-2	315	600 +10 %	1	3RT10 64	3RT10 44	3RT10 54
3RW44 44	250	3NE1 331-2	350	460 +10 %	2	3RT10 65	3RT10 44	3RT10 55
3RW44 45	313	3NE1 333-2	450	690 +5 %	2	3RT10 75	3RT10 54	3RT10 56
3RW44 46	356	3NE1 334-2	500	690 +5 %	2	3RT10 75	3RT10 54	3RT10 56
3RW44 47	432	3NE1 435-2	560	690 +5 %	3	3RT10 76	3RT10 55	3RT10 64

1) If the ramp-down function "Combined braking" is selected, no braking contactor is required.
If the ramp-down function "DC braking" is selected, a braking contactor must be used in addition (see table for type).
For applications with large centrifugal masses ($J_{Load} > J_{Motor}$) we recommend the function "DC braking".

2) Additional auxiliary relay K4:
LZX:RT4A4T30
(3RW44 soft starter with rated control supply voltage 230 V AC),
LZX:RT4A4S15
(3RW44 soft starter with rated control supply voltage 115 V AC).

3) The types of coordination are explained in more detail under Fuseless Load Feeders on page 6/48.

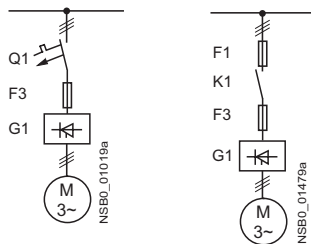
Inline circuit fused version with 3NE or 3NC SITOR semiconductor fuse
 (semiconductor protection by fuse, lead and overload protection by motor starter protector)

Soft starters		Semiconductor fuses, minimum			Semiconductor fuses, maximum			Semiconductor fuses (cylinder)		
G1 Type	Rated current A	F3 Type	Rated current A	Size	F3 Type	Rated current A	Size	F3 Type	Rated current A	Size
Type of coordination 2³⁾: I_q = 65 kA										
3RW44 22	29	3NE4 120	80	0	3NE4 121	100	0	3NC2 280	80	22 x 58
3RW44 23	36	3NE4 121	100	0	3NE4 122	125	0	3NC2 200	100	22 x 58
3RW44 24	47	3NE4 121	100	0	3NE4 122	125	0	3NC2 200	100	22 x 58
3RW44 25	57	3NE4 122	125	0	3NE4 124	160	0			
3RW44 26	77	3NE4 124	160	0	3NE4 124	160	0			
3RW44 27	93	3NE3 224	160	1	3NE3 333	450	2			
3RW44 34	113	3NE3 225	200	1	3NE3 335	560	2			
3RW44 35	134	3NE3 225	200	1	3NE3 335	560	2			
3RW44 36	162	3NE3 227	250	1	3NE3 333	450	2			
3RW44 43	203	3NE3 230-0B	315	1	3NE3 333	450	2			
3RW44 44	250	3NE3 230-0B	315	1	3NE3 333	450	2			
3RW44 45	313	3NE3 233	450	1	3NE3 336	630	2			
3RW44 46	356	3NE3 333	450	2	3NE3 336	630	2			
3RW44 47	432	3NE3 335	560	2	3NE3 338-8	800	2			

Soft starters	Line contactors up to 400 V (optional)	Braking contactors ¹⁾²⁾		Motor starter protectors/circuit-breakers		Line protection			
		(for typical circuit see page 6/46)		440 V +10 %	Rated current	690 V +5 %	Rated current	Size	
G1 Type	K1 Type			Q1 Type	A	F1 Type	A		
Type of coordination 2³⁾: 3RW44 22 ... 3RW44 27: I_q = 32 kA; 3RW44 34 and 3RW44 35: I_q = 16 kA; 3RW44 36 ... 3RW44 47: I_q = 65 kA									
3RW44 22	29	3RT10 34	3RT15 26	-	3RV10 42-4HA10	50	3NA3 820-6	50	00
3RW44 23	36	3RT10 35	3RT15 26	-	3RV10 42-4JA10	63	3NA3 822-6	63	00
3RW44 24	47	3RT10 36	3RT15 35	-	3RV10 42-4KA10	75	3NA3 824-6	80	00
3RW44 25	57	3RT10 44	3RT15 35	-	3RV10 42-4LA10	90	3NA3 830-6	100	00
3RW44 26	77	3RT10 45	3RT10 24	3RT10 35	3RV10 42-4MA10	100	3NA3 132-6	125	1
3RW44 27	93	3RT10 46	3RT10 25	3RT10 36	3RV10 42-4MA10	100	3NA3 136-6	160	1
3RW44 34	113	3RT10 54	3RT10 34	3RT10 44	3VL17 16-2DD36	160	3NA3 244-6	250	2
3RW44 35	134	3RT10 55	3RT10 36	3RT10 45	3VL17 16-2DD36	160	3NA3 244-6	250	2
3RW44 36	162	3RT10 56	3RT10 44	3RT10 45	3VL37 25-2DC36	250	3NA3 365-6	500	3
3RW44 43	203	3RT10 64	3RT10 44	3RT10 54	3VL47 31-3DC36	315	2 x 3NA3 354-6	2 x 355	3
3RW44 44	250	3RT10 65	3RT10 44	3RT10 55	3VL47 31-3DC36	315	2 x 3NA3 354-6	2 x 355	3
3RW44 45	313	3RT10 75	3RT10 54	3RT10 56	3VL47 40-3DC36	400	2 x 3NA3 365-6	2 x 500	3
3RW44 46	356	3RT10 75	3RT10 54	3RT10 56	3VL47 40-3DC36	400	2 x 3NA3 365-6	2 x 500	3
3RW44 47	432	3RT10 76	3RT10 55	3RT10 64	3VL57 50-3DC36	500	2 x 3NA3 365-6	2 x 500	3

1) If the ramp-down function "Combined braking" is selected, no braking contactor is required.
 If the ramp-down function "DC braking" is selected, a braking contactor must be used in addition (see table for type).
 For applications with large centrifugal masses ($J_{Load} > J_{Motor}$) we recommend the function "DC braking".

2) Additional auxiliary relay K4:
 LZX:RT4A4T30
 (3RW44 soft starter with rated control supply voltage 230 V AC),
 LZX:RT4A4S15
 (3RW44 soft starter with rated control supply voltage 115 V AC).

3) The types of coordination are explained in more detail under Fuseless Load Feeders on page 6/48.



3RW Soft Starters

3RW44 for High-Feature applications

Inside-delta circuit fuseless version

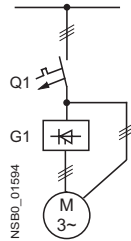

Soft starters

G1 Type	Rated current A
------------	--------------------

Motor starter protectors/ circuit-breakers

Q1 Type	Rated current A
------------	--------------------

Type of coordination 1¹⁾

G1 Type	Rated current A	Q1 Type	Rated current A
3RW44 22	50	3RV10 42-4KA10	75
3RW44 23	62	3RV10 42-4LA10	90
3RW44 24	81	3RV10 42-4MA10	100
3RW44 25	99	3VL27 16-2DC36	160
3RW44 26	133	3VL37 20-2DC36	200
3RW44 27	161	3VL37 20-2DC36	200
3RW44 34	196	3VL37 25-2DC36	250
3RW44 35	232	3VL47 31-3DC36	315
3RW44 36	281	3VL47 40-3DC36	400
3RW44 43	352	3VL47 40-3DC36	400
3RW44 44	433	3VL57 50-3DC36	500
3RW44 45	542	3WL12 08	800
3RW44 46	617	3WL12 08	800
3RW44 47	748	3WL12 10	1000

Inside-delta circuit fused version (line protection only)

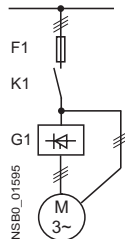

Soft starters

G1 Type	Rated current Soft starters A
------------	-------------------------------------

Line protection

F1 Type	Rated current A	Size
------------	--------------------	------

Line contactors up to 400 V

K1 Type

Type of coordination 1¹⁾

G1 Type	Rated current A	F1 Type	Rated current A	Size	K1 Type
3RW44 22	50	3NA3 824-6	80	00	3RT10 36-1AP04
3RW44 23	62	3NA3 830-6	100	00	3RT10 44-1AP04
3RW44 24	81	3NA3 132-6	125	1	3RT10 46-1AP04
3RW44 25	99	3NA3 136-6	160	1	3RT10 54-1AP36
3RW44 26	133	3NA3 240-6	200	2	3RT10 55-6AP36
3RW44 27	161	3NA3 244-6	250	2	3RT10 56-6AP36
3RW44 34	196	3NA3 360-6	400	3	3RT10 64-6AP36
3RW44 35	232	3NA3 360-6	400	3	3RT10 65-6AP36
3RW44 36	281	2 x 3NA3 360-6	2 x 400	3	3RT10 66-6AP36
3RW44 43	352	2 x 3NA3 365-6	2 x 500	3	3RT10 75-6AP36
3RW44 44	433	2 x 3NA3 365-6	2 x 500	3	3RT10 76-6AP36
3RW44 45	542	3 x 3NA3 365-6	3 x 500	3	3TF68 44-OCM7
3RW44 46	617	3 x 3NA3 365-6	3 x 500	3	3TF68 44-OCM7
3RW44 47	748	3 x 3NA3 365-6	3 x 500	3	3TF69

1) The types of coordination are explained in more detail under Fuseless Load Feeders on page 6/48.

Inside-delta circuit fused version with 3NE or 3NC SITOR fuses
(semiconductor protection by fuse, lead and overload protection by motor starter protector)

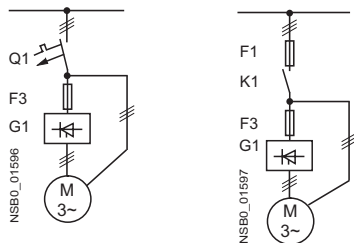

Soft starters	Semiconductor fuses, minimum			Semiconductor fuses, maximum			Semiconductor fuses (cylinder)			
	Rated current	Rated current	Size	Rated current	Size	Rated current	Size			
G1 Type	A	F3 Type	A	F3 Type	A	F3 Type	A			
Type of coordination 2¹⁾										
3RW44 22	50	3NE4 120	80	0	3NE4 121	100	0	3NC2 280	80	22 x 58
3RW44 23	62	3NE4 121	100	0	3NE4 122	125	0	3NC2 200	100	22 x 58
3RW44 24	81	3NE4 121	100	0	3NE4 122	125	0	3NC2 200	100	22 x 58
3RW44 25	99	3NE4 122	125	0	3NE4 124	160	0			
3RW44 26	133	3NE4 124	160	0	3NE4 124	160	0			
3RW44 27	161	3NE3 224	160	1	3NE3 333	450	2			
3RW44 34	196	3NE3 225	200	1	3NE3 335	560	2			
3RW44 35	232	3NE3 225	200	1	3NE3 335	560	2			
3RW44 36	281	3NE3 227	250	1	3NE3 333	450	2			
3RW44 43	352	3NE3 230-0B	315	1	3NE3 333	450	2			
3RW44 44	433	3NE3 230-0B	315	1	3NE3 333	450	2			
3RW44 45	542	3NE3 233	450	1	3NE3 336	630	2			
3RW44 46	617	3NE3 333	450	2	3NE3 336	630	2			
3RW44 47	748	3NE3 335	560	2	3NE3 338-8	800	2			

Soft starters	Rated current	Line contactors up to 400 V (optional)	Motor starter protectors/ circuit-breakers		Line protection		
			440 V +10 %	Rated current	690 V +5 %	Rated current	Size
G1 Type	A	K1 Type	Q1 Type	A	F1 Type	A	
Type of coordination 2¹⁾							
3RW44 22	50	3RT10 36-1AP04	3RV10 42-4KA10	75	3NA3 824-6	80	00
3RW44 23	62	3RT10 44-1AP04	3RV10 42-4LA10	90	3NA3 830-6	100	00
3RW44 24	81	3RT10 46-1AP04	3RV10 42-4MA10	100	3NA3 132-6	125	1
3RW44 25	99	3RT10 54-1AP36	3VL27 16-2DC36	160	3NA3 136-6	160	1
3RW44 26	133	3RT10 55-6AP36	3VL27 16-2DC36	160	3NA3 240-6	200	2
3RW44 27	161	3RT10 56-6AP36	3VL37 20-2DC36	200	3NA3 244-6	250	2
3RW44 34	196	3RT10 64-6AP36	3VL37 25-2DC36	250	3NA3 360-6	400	3
3RW44 35	232	3RT10 65-6AP36	3VL47 31-3DC36	315	3NA3 360-6	400	3
3RW44 36	281	3RT10 66-6AP36	3VL47 40-3DC36	400	2 x 3NA3 360-6	2 x 400	3
3RW44 43	352	3RT10 75-6AP36	3VL47 40-3DC36	400	2 x 3NA3 365-6	2 x 500	3
3RW44 44	433	3RT10 76-6AP36	3VL57 50-3DC36	500	2 x 3NA3 365-6	2 x 500	3
3RW44 45	542	3TF68 44-0CM7	3WL12 08	800	3 x 3NA3 365-6	3 x 500	3
3RW44 46	617	3TF68 44-0CM7	3WL12 08	800	3 x 3NA3 365-6	3 x 500	3
3RW44 47	748	3TF69	3WL12 10	1000	3 x 3NA3 365-6	3 x 500	3

1) The types of coordination are explained in more detail under Fuseless Load Feeders on page 6/48.



3RW44 for High-Feature applications

Characteristic curves

Motor protection tripping characteristics for 3RW44 (with symmetry)

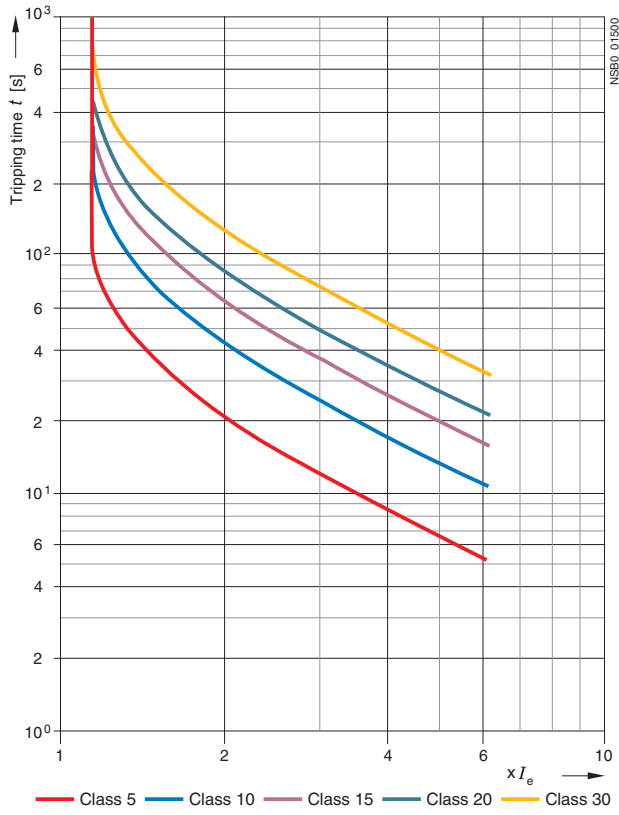

More information

Application examples for normal starting (Class 10)

Normal starting Class 10 (up to 20 s with 350 % $I_{n \text{ motor}}$),
The soft starter rating can be selected to be as high as the rating of the motor used

Application	Conveyor belts	Roller conveyors	Compressors	Small ventilators	Pumps	Hydraulic pumps
Starting parameters						
• Voltage ramp and current limiting						
- Starting voltage	70	60	50	30	30	30
- Starting time	10	10	10	10	10	10
- Current limit value	Deactivated	Deactivated	$4 \times I_M$	$4 \times I_M$	Deactivated	Deactivated
• Torque ramp						
- Starting torque	60	50	40	20	10	10
- End torque	150	150	150	150	150	150
- Starting time	10	10	10	10	10	10
• Breakaway pulse	Deactivated (0 ms)	Deactivated (0 ms)	Deactivated (0 ms)	Deactivated (0 ms)	Deactivated (0 ms)	Deactivated (0 ms)
Ramp-down mode	Smooth ramp-down	Smooth ramp-down	Free ramp-down	Free ramp-down	Pump ramp-down	Free ramp-down

Application examples for heavy starting (Class 20)

Heavy starting Class 20 (up to 40 s with 350 % $I_{n \text{ motor}}$),
The soft starter has to be selected one rating class higher than the motor used

Application	Stirrers	Centrifuges	Milling machines
Starting parameters			
• Voltage ramp and current limiting			
- Starting voltage	30	30	30
- Starting time	30	30	30
- Current limit value	$4 \times I_M$	$4 \times I_M$	$4 \times I_M$
• Torque ramp			
- Starting torque	30	30	30
- End torque	150	150	150
- Starting time	30	30	30
• Breakaway pulse	Deactivated (0 ms)	Deactivated (0 ms)	Deactivated (0 ms)
Ramp-down mode	Free ramp-down	Free ramp-down	Free ramp-down or DC braking

Application examples for very heavy starting (Class 30)

Very heavy starting Class 30 (up to 60 s with 350 % $I_{n \text{ motor}}$),
The soft starter has to be selected two rating classes higher than the motor used

Application	Large ventilators	Mills	Breakers	Circular saw/bandsaws
Starting parameters				
• Voltage ramp and current limiting				
- Starting voltage	30	50	50	30
- Starting time	60	60	60	60
- Current limit value	$4 \times I_M$	$4 \times I_M$	$4 \times I_M$	$4 \times I_M$
• Torque ramp				
- Starting torque	20	50	50	20
- End torque	150	150	150	150
- Starting time	60	60	60	60
• Breakaway pulse	Deactivated (0 ms)	80 %, 300 ms	80 %, 300 ms	Deactivated (0 ms)
Ramp-down mode	Free ramp-down	Free ramp-down	Free ramp-down	Free ramp-down

Note:

These tables present sample setting values and device sizes. They are intended only for the purposes of information and are not binding. The setting values depend on the application in question and must be optimized during commissioning. The soft starter dimensions should be checked where necessary with the Win-Soft Starter software or with the help of Technical Assistance.



3RW44 for High-Feature applications

Circuit concept

The SIRIUS 3RW44 soft starters can be operated in two different types of circuit.

- **Inline circuit**

The switching devices for isolating and protecting the motor are simply connected in series with the soft starter. The motor is connected to the soft starter with three leads.

- **Inside-delta circuit**

The wiring is similar to that of wye-delta starters. The phases of the soft starter are connected in series with the individual motor windings. The soft starter then only has to carry the phase current, amounting to about 58 % of the rated motor current (conductor current).

Comparison of the types of circuit

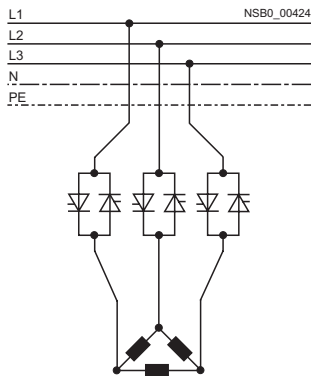

Inline circuit:

Rated current I_e corresponds to the rated motor current I_n , 3 leads to the motor

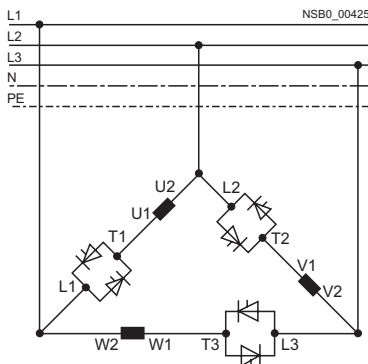

Inside-delta circuit:

Rated current I_e corresponds to approx. 58 % of the rated motor current I_n , 6 leads to the motor (as with wye-delta starters)

Which circuit?

Using the inline circuit involves the lowest wiring complexity. If the soft starter to motor connections are long, this contact sequence is preferable.

With the inside-delta circuit there is double the wiring complexity but a smaller size of device can be used at the same rating.

Thanks to the possibility of switching between the inline circuit and inside-delta circuit, the most favorable solution can always be chosen.

The braking function is possible only in the inline circuit.

Configuration

The 3RW44 solid-state soft starters are designed for normal starting. In case of heavy starting or increased starting frequency, a larger device must be selected.

For long starting times it is recommended to have a PTC thermistor detector in the motor. This also applies for the ramp-down modes smooth ramp-down, pump ramp-down and DC braking, because during the ramp-down time in these modes, an additional current loading applies in contrast to free ramp-down.

In the motor feeder between the SIRIUS 3RW soft starter and the motor, no capacitive elements are permitted (e.g. no reactive-power compensation equipment). In addition, neither static systems for reactive-power compensation nor dynamic PFC (Power Factor Correction) must be operated in parallel during starting and ramp-down of the soft starter. This is important to prevent faults arising on the compensation equipment and/or the soft starter.

All elements of the main circuit (such as fuses and controls) should be dimensioned for direct starting, following the local short-circuit conditions. Fuses, switching devices and overload relays must be ordered separately.

The harmonic component load for starting currents must be taken into consideration for the selection of motor starter protector (selection of release).

Serial PC interface RS 232 and parameterizing and operating software Soft Starter ES

The solid-state 3RW44 soft starters have a PC interface for communicating with the Soft Starter ES smart software and an operating and monitoring module.

Manual for SIRIUS 3RW44

Besides containing all important information on configuring, commissioning and servicing, the manual also contains suggested circuits and the technical specifications for all devices.

Win-Soft Starter selection and simulation program

With this software, you can simulate and select all Siemens soft starters, taking into account various parameters such as mains properties, motor and load data, and special application requirements.

The software is a valuable tool, which makes complicated, lengthy manual calculations for determining the required soft starters superfluous.

You can order the CD-ROM under the following order number: Order No.: E20001-D1020-P302-V2-7400.

More information can be found on the Internet at

<http://www.siemens.com/softstarter>

SIRIUS soft starter training course (SD-SIRIUSO)

Siemens offers a 2-day training course on the SIRIUS solid-state soft starters to keep customers and own personnel up-to-date on configuring, commissioning and servicing issues.

Please direct enquiries and applications to:

Training Center
I&S IS E&C TC
Werner-von-Siemens-Str. 65
D-91052 Erlangen
Telephone: ++49 (0) 9131 729262
Telefax: ++49 (0) 9131 728172
sibrain@erl9.siemens.de
<http://www.siemens.com/sibrain>

Dimensional drawings

3RW30/3RW31 for standard applications

3RW30 03-1.... (screw terminals)

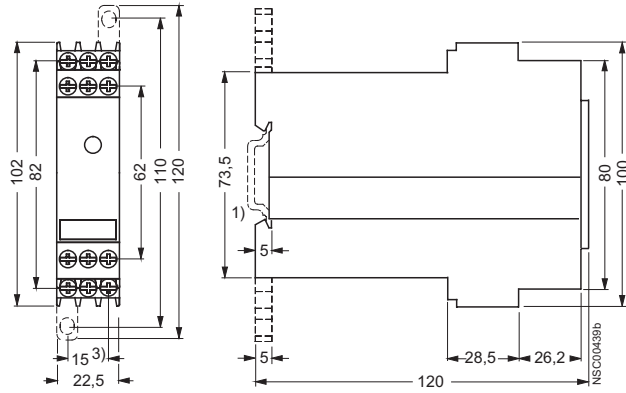

3RW30 03-2.... (spring-loaded terminals)

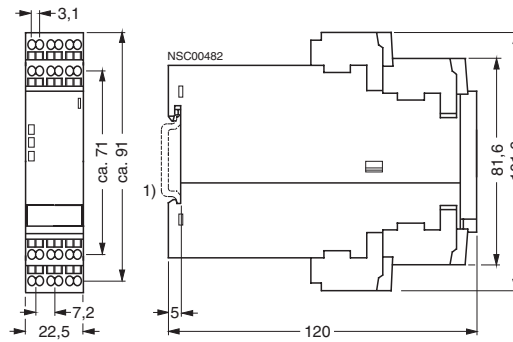

3RW30 1.

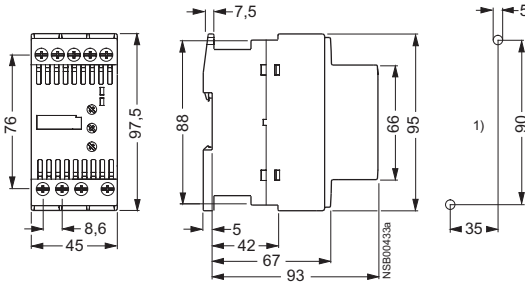

3RW30 2. and 3RW31 2.

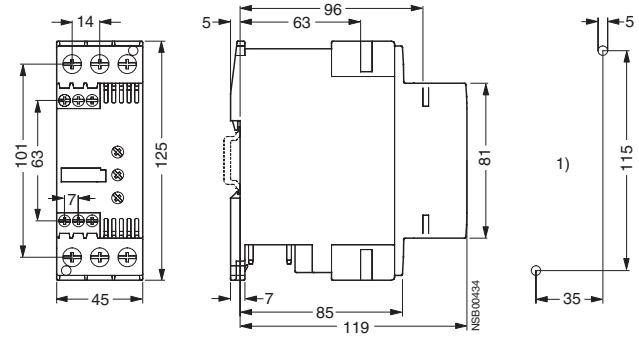

3RW30 3.

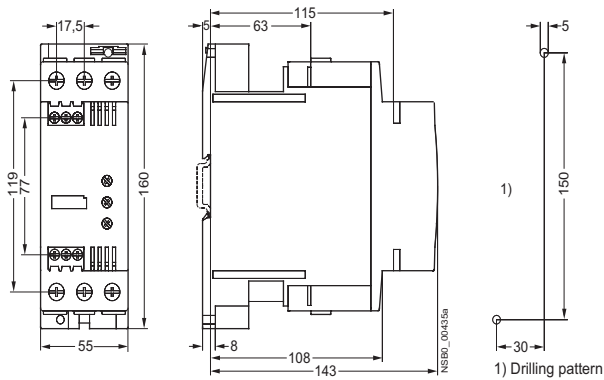

3RW30 4.

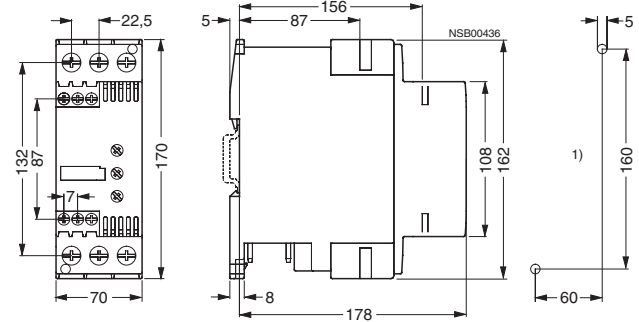

1) Drilling pattern

3) Connection dimension for screw terminals. Screw connection with 2 3RP19 03 push-in lugs for each 3TK28 device.

3RW Soft Starters

Project planning aids

3RW40 for standard applications

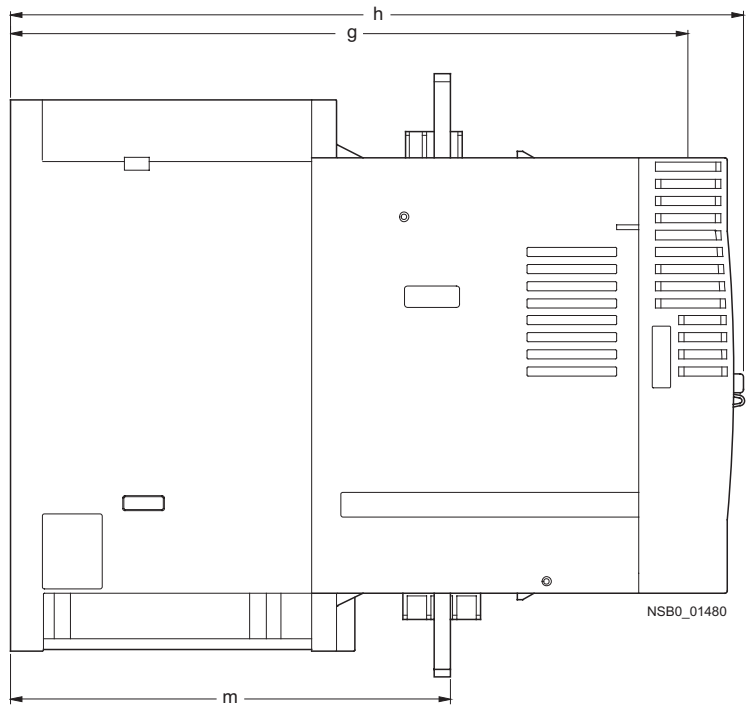
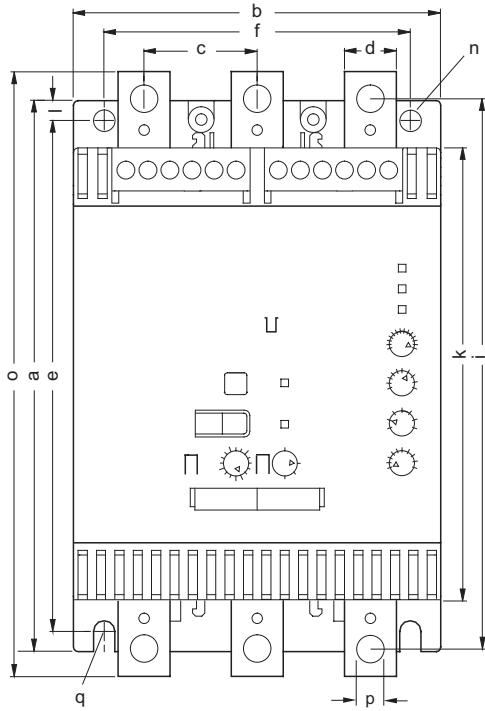

NSB0_01480

Type/Dimension (mm)	a	b	c	d	e	f	g	h	i	k	l	m	N	o	p	q
3RW40 5.	180	120	37	17	167	100	223	250	180	148	6.5	153	7	198	9	M6, 10 Nm
3RW40 7.	210	160	48	25	190	140	240	278	205	166	10	166	9	230	11	M8, 15 Nm

6

3RW44 for High-Feature applications

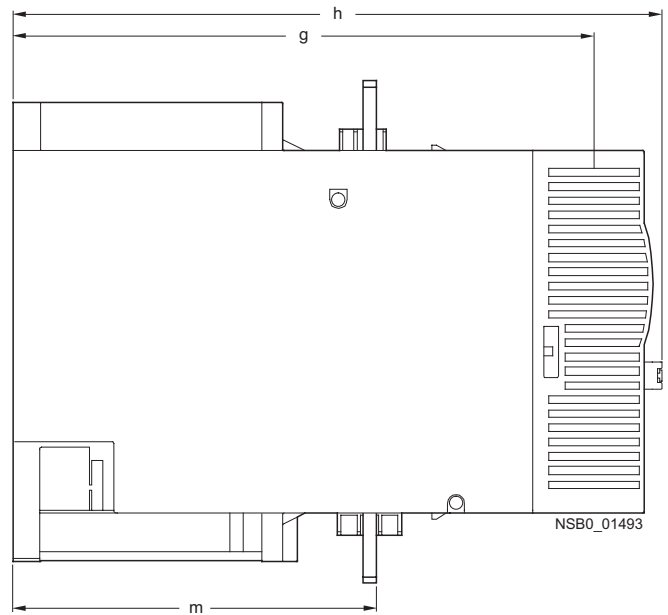
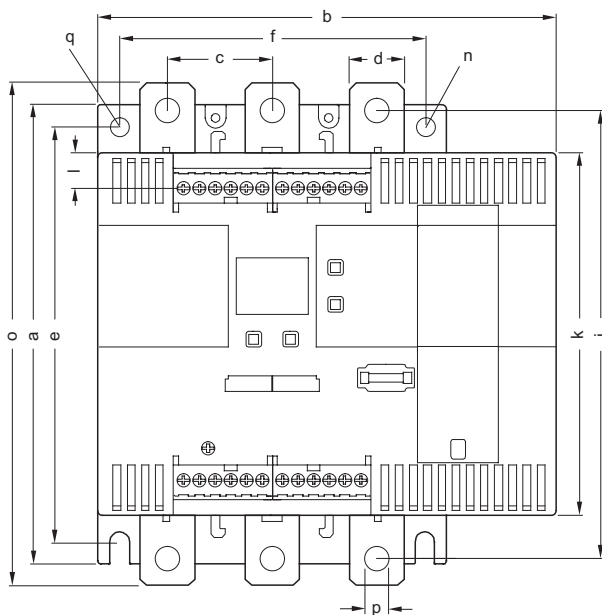

NSB0_01493

Type/Dimension (mm)	a	b	c	d	e	f	g	h	i	k	l	m	N	o	p	q
3RW44 2.	180	170	37	11	167	100	240	270	180	148	7.5	153	7	184	6.6	M6, 10 Nm
3RW44 3.	180	170	37	17	167	100	240	270	180	148	7.5	153	7	198	9	M6, 10 Nm
3RW44 4.	210	210	48	25	190	140	269	298	205	166	16	166	9	230	11	M8, 15 Nm

Schematics

3RW30/3RW31 connection examples for actuation with switches or auxiliary contacts

Control using switches

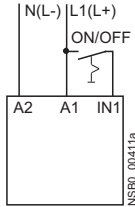

Control using contactor contacts (for control of size S00 with buttons)

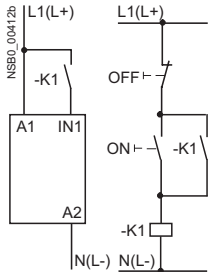

Control using switches on versions for pole-changing motors (for 3RW31 soft starters only)

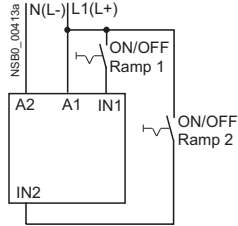

Control using contactor contacts on versions for pole-changing motors (for 3RW31 soft starters only)

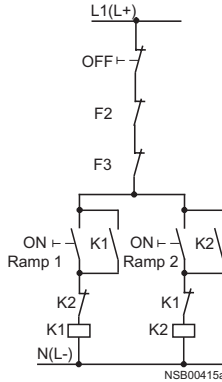
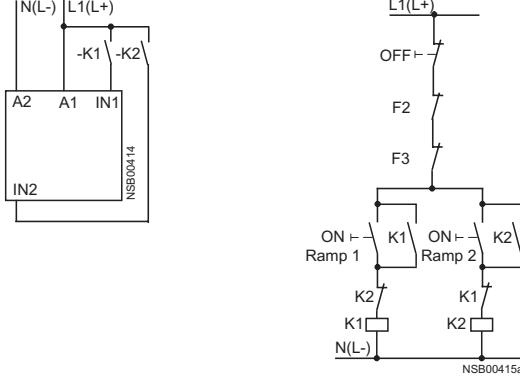

3RW30/3RW31 connection example for control with pushbuttons

(sizes S0, S2, and S3 only)

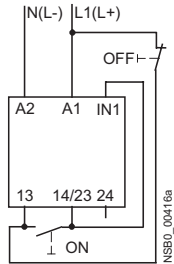

Project planning aids

3RW30/3RW31 connection examples for main circuit¹⁾

3RW30
3-phase motors

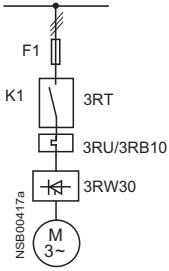

3RW30
3-phase motors
with motor starter
protector

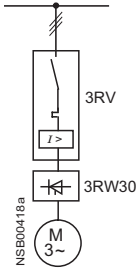

3RW30
1-phase motors
with 3RV motor starter
protector

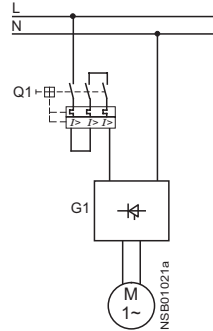

3RW31

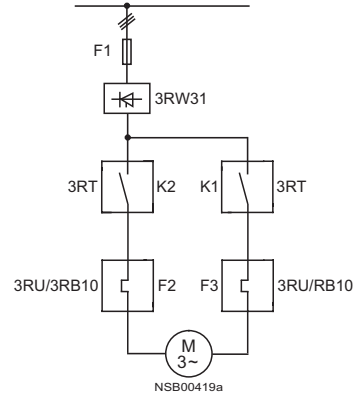

3RW30/3RW31 connection example: AS-Interface load feeder with SIRIUS soft starter

Main circuit

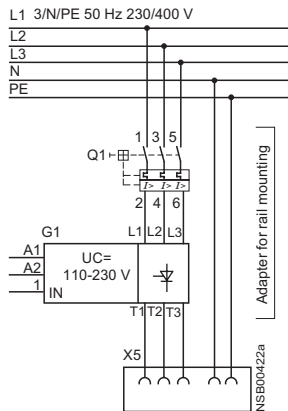

Q1 = Motor starter protector
G1 = 3RW30 1. SIRIUS soft starter
X5 = Power connector

Control circuit

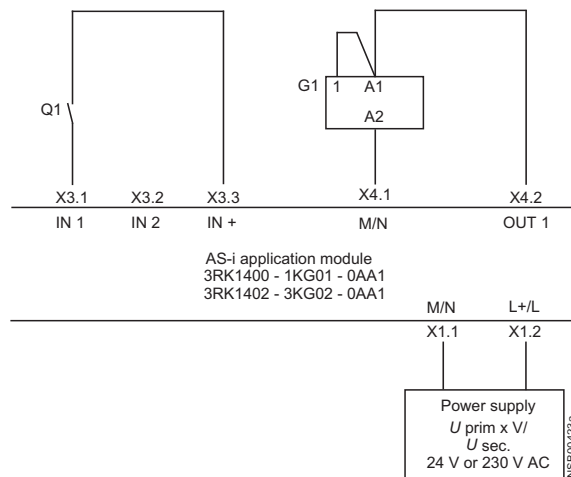

1) As an alternative, the motor feeder can also be installed as a fuseless or as a fused version. Fuse and switching device coordination, see Technical Specifications. The wiring diagrams are provided only as examples.

3RW40 connection examples for control circuit

Control by switch using internal 24 V DC supply

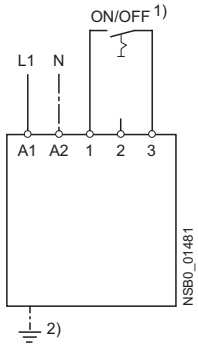

External power supply

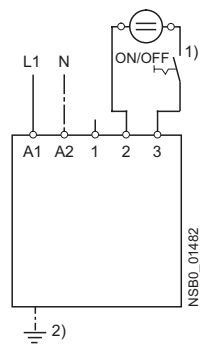

3RW40 connection examples for main circuit³⁾

3RW40 – 3-phase motor with fuse 3NA/3NE

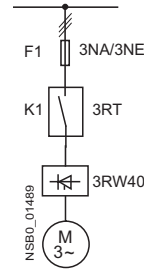

3VL circuit-breakers

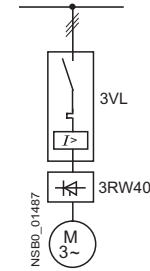

Control by pushbutton

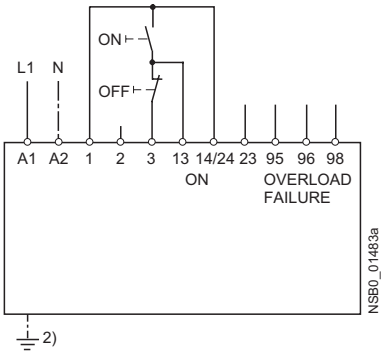

of a main contactor

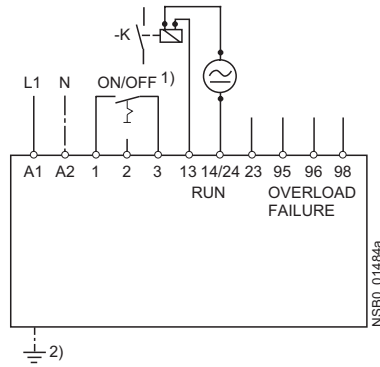

- 1) **Caution: Risk of restarting**
When operating with a switch (ON/OFF) a new, automatic restart will take place automatically if the start command is still active at terminal 3.
- 2) Grounding necessary for fan connection to 3RW40 5....
- 3) As an alternative, the motor feeder can also be installed as a fuseless or as a fused version. Fuse and switching device coordination, see Technical Specifications. The wiring diagrams are provided only as examples.

Project planning aids

3RW44 connection examples for main and control circuits

Main circuit

Possibility 1a:
Inline circuit with motor starter protector and SITOR fuse
(semiconductor protection only)

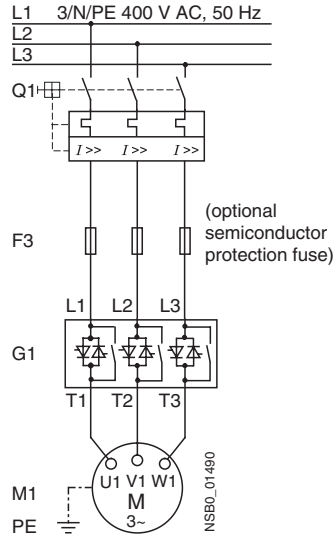

Control circuit

Possibility 1:
Control by pushbutton

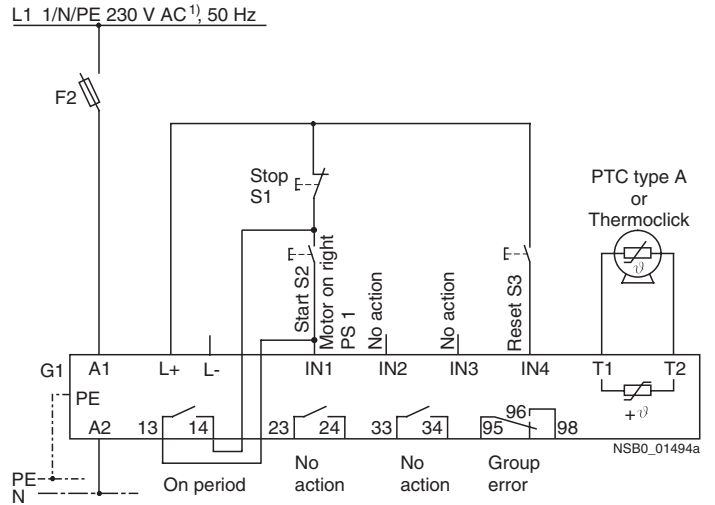

Main circuit

Possibility 1b:
Inline circuit with full-range protection
(line and semiconductor protection)

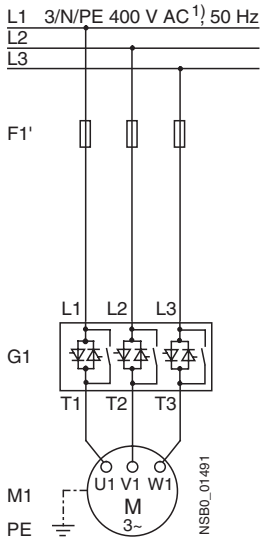

Possibility 1c:
Inline circuit with line and SITOR fuse
(semiconductor protection only)

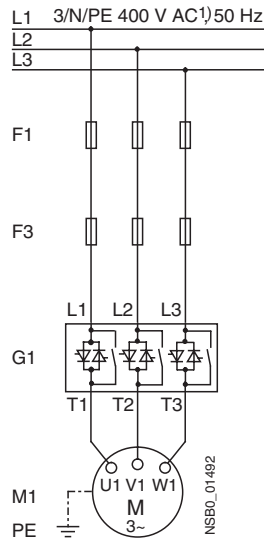

1) Permissible values for main and control voltage, see Technical Specifications.

Main circuit

Possibility 2:
Inline circuit with main contactor

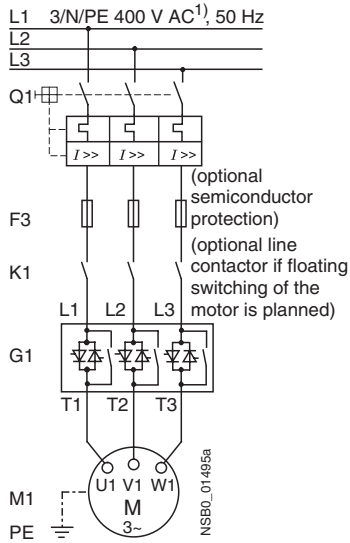

1) Permissible values for main and control voltage, see Technical Specifications.

2) **Caution. Risk of restarting!**

The start command (e.g. from the PLC) must be reset prior to a reset command because a new, automatic restart will take place automatically if a start command is active after the reset command. This applies especially in case of motor protection tripping. For safety reasons we recommend incorporating the group error output (terminals 95 and 96) in the controller.

Control circuit

Possibility 2:
Control of a main contactor and control by means of PLC

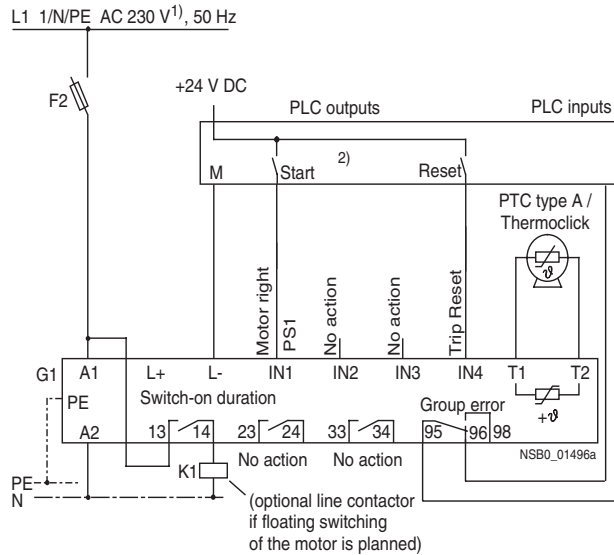

Project planning aids

Main circuit

Possibility 3a:
Inline circuit with ramp-down function DC braking³⁾
(for device types 3RW44 22 to 3RW44 25)

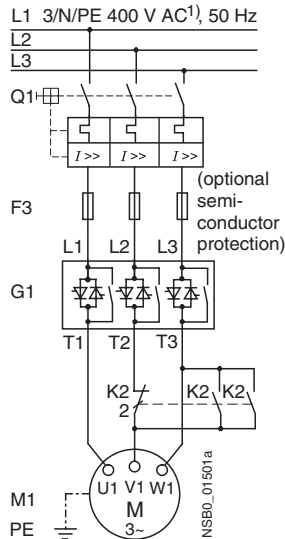

Control circuit

Possibility 3a:
Control of the DC braking contactor³⁾

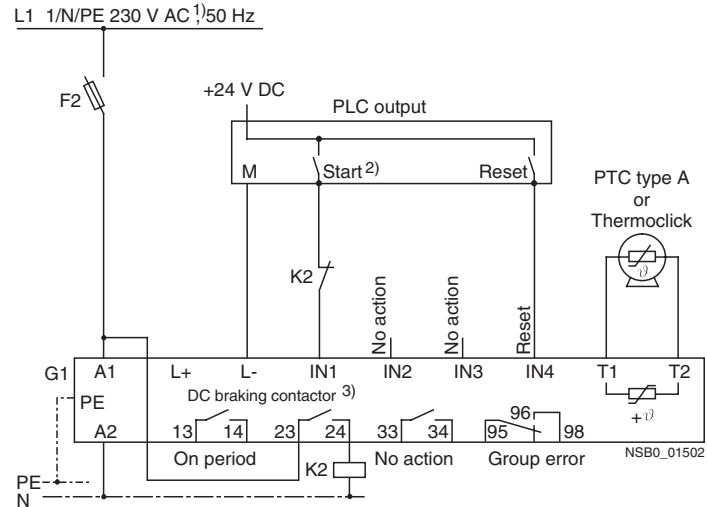

Main circuit

Possibility 3b:
Inline circuit with ramp-down function DC braking³⁾
(for device types 3RW44 26 to 3RW44 47)

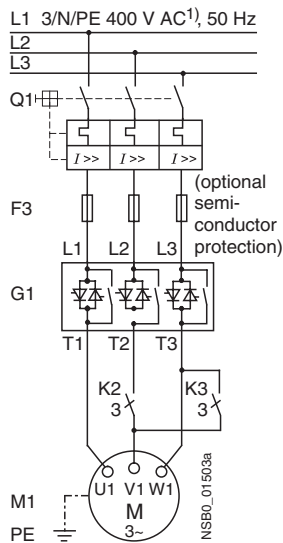

Control circuit

Possibility 3b:
Control of the DC braking contactor³⁾

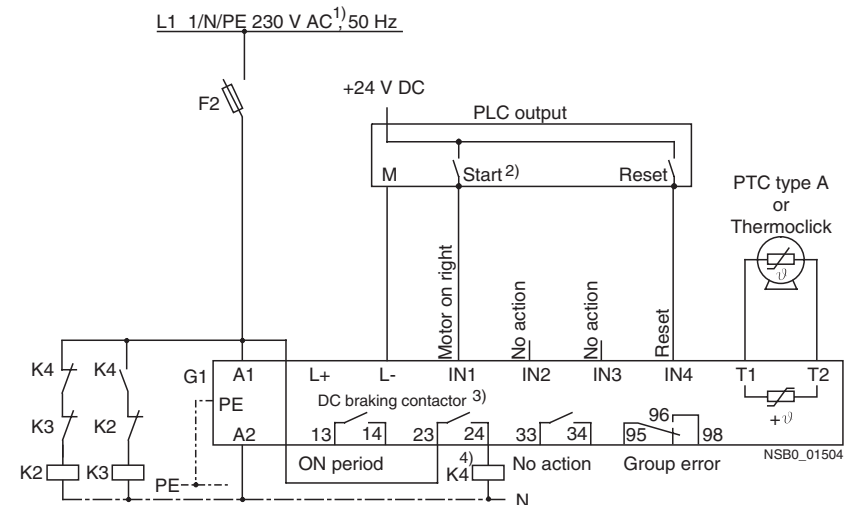

1) Permissible values for main and control voltage, see Technical Specifications.

2) Caution. Risk of restarting!

The start command (e.g. from the PLC) must be reset prior to a reset command because a new, automatic restart will take place automatically if a start command is active after the reset command. This applies especially in case of motor protection tripping. For safety reasons we recommend incorporating the group error output (terminals 95 and 96) in the controller.

3) If the ramp-down function "Combined braking" is selected, no braking contactor is required.

If the ramp-down function "DC braking" is selected, a braking contactor must be used in addition. Type, see Fuse Coordination (inline circuit) on pages 6/31 to 6/33.

For applications with large centrifugal masses ($J_{Load} > J_{Motor}$) we recommend the function "DC braking". The output 2 must be switched over to "DC braking contactor".

4) Auxiliary relay K4, e.g.:

LZX:RT4A4T30 (230 V AC rated control supply voltage),
LZX:RT4A4S15 (115 V AC rated control supply voltage).

Main circuit

Possibility 4a:
Inside-delta circuit

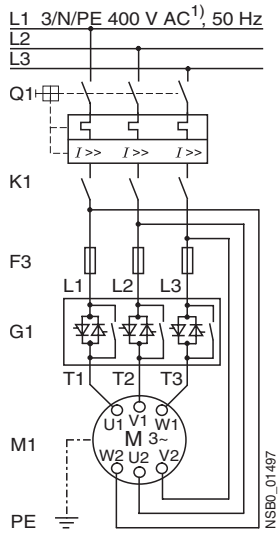

Possibility 4b:
Change of direction of rotation for
inside-delta circuit

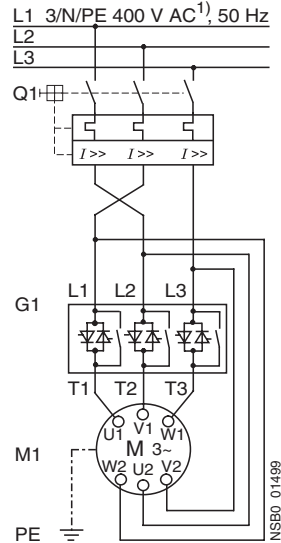

Control circuit

Possibility 4:
Control by means of PLC

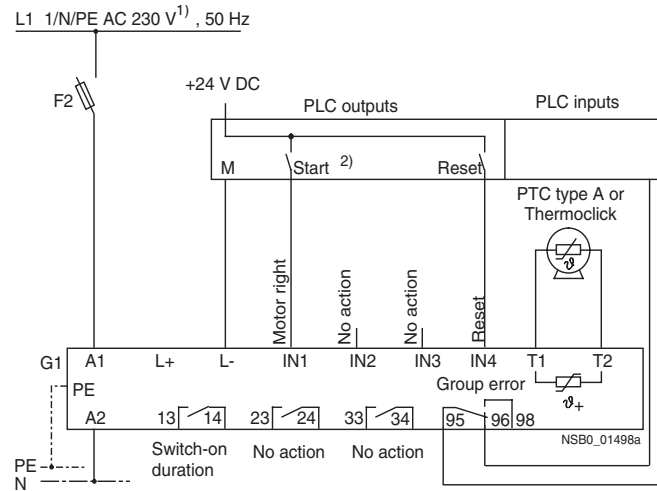

1) Permissible values for main and control voltage,
see Technical Specifications.

2) Caution. Risk of restarting!

The start command (e.g. from the PLC) must be reset prior to a reset command because a new, automatic restart will take place automatically if a start command is active after the reset command. This applies especially in case of motor protection tripping. For safety reasons we recommend incorporating the group error output (terminals 95 and 96) in the controller.