

**TORQ-MASTER 2000**

**Another leap forward in  
Soft-Start Technology**

# **TQM2000**

# **Instruction Manual**

**Ralspeed Ltd**

**Unit 6 Red Rose Court**

**Sunnyhurst Road**

**Blackburn BB2 1PS**

**Tel: 01254 582345 Fax: 01254 668414**

**[Http://www.ralspeed.com](http://www.ralspeed.com) E-mail: [info@ralspeed.com](mailto:info@ralspeed.com)**

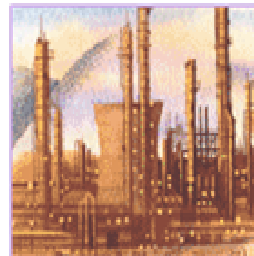

# INDEX

<u>SECTION</u>	<u>TITLE</u>	<u>PAGE</u>	<u>SECTION</u>	<u>TITLE</u>	<u>PAGE</u>
	INDEX	1			
	<i>SIDE NOTES AND TABLES</i>	2	10.0	<b>TROUBLE SHOOTING</b>	26
1.0	<b>SAFETY</b>	3	10.1	THE SOFT STARTER DOES NOT RUN	26
1.2	IN-BUILT SAFETY SYSTEMS	3	10.2	THE STARTER TRIPS ON FIRING FAULT	27
1.3	SAFETY CONSIDERATIONS	3	10.3	THE STARTER TRIPS ON OVERLOAD	28
1.4	USER RESPONSIBILITIES	3	FAULT		29
1.4	HOW TO USE THIS MANUAL	3	10.4	THE STARTER TRIPS ON SHEARPIN FAULT	30
1.5	STANDARDS	3	10.5	THE STARTER DOES NOT ACCELERATE	31
			10.6	THE STARTER DOES NOT SOFT STOP	32
			10.7	THE STARTER DOES NOT BRAKE STOP	
	<i>SIDE NOTES AND TABLES</i>	4			33
2.0	<b>INSTALLATION</b>	5	11.0	<b>SYSTEM DRAWINGS INDEX</b>	
2.1	UNIT TYPE	5			34
2.2	LOCATION (CHASSIS TYPE)	5	TQM2K-B	BASIC SYSTEM-PUSHBUTTONS.	34
2.3	LOCATION (COMPLETE STARTER)	5	TQM2K-B	BASIC SYSTEM-RELAY.	35
2.4	CABLING	5	TQM2K-B	EMERGENCY STOP SYSTEM.	35
2.5	BYPASS CONTACTORS	5	TQM2K-B	EMERGENCY STOP SYSTEM-RELAY.	36
	CIRCUIT DIAGRAMS	6	TQM2KB	EMERGENCY STOP SYSTEM-	36
2.6	POWER TERMINALS	7	BUTTONS		
2.7	CONTROL TERMINALS	7	TQM2KB	EMERGENCY STOP SYSTEM-RELAY	
	CIRCUIT DIAGRAMS	8			
2.8	C.T TERMINALS	9			
2.9	J.S.T. SOCKET	9			
2.10	RELAY TERMINALS	9			
2.11	GATE\CATHODE TERMINALS	9			
	<i>SIDE NOTES AND TABLES</i>	10			
3.0	<b>KEYPAD AND DISPLAY</b>	11			
3.1	LAYOUT	11			
3.2	HOW TO USE THE KEYPAD	11			
	<i>SIDE NOTES AND TABLES</i>	12			
4.0	<b>SCREENS</b>	13			
4.1	START-UP SCREENS	13			
4.2	INFORMATION SCREENS	13			
	GRAPHS	14			
5.0	USER MENU	15			
5.1	MOTOR PROTECTION	15			
5.2	MOTOR START MODES	15			
	GRAPHS	16			
5.3	CONTROL	17			
5.4	MOTOR STOP MODES	17			
6.0	NOTES-OPTIONS MENU	18			
6.1	BYPASS CONTACTOR	19			
6.2	UNDERLOAD TRIP	19			
6.3	SHEAR-PIN TRIP	19			
6.4	AUTO RESET\RESTART	19			
6.5	OVERLOAD PRE-ALARM	19			
	CIRCUIT DIAGRAMS	20			
7.0	PROGRAMMABLE INPUTS	21			
7.1	PROGRAM 1	21			
7.2	PROGRAM 2	21			
7.3	PROGRAM 3	21			
7.4	PROGRAM 4	21			
7.5	LIST OF PROGRAM INPUTS	21			
	CIRCUIT DIAGRAMS	22			
8.0	PROGRAMMABLE OUTPUTS	23			
8.1	PROGRAMMABLE RELAY 'A'	23			
8.2	PROGRAMMABLE RELAY 'B'	23			
8.3	PROGRAMMABLE FUNCTIONS	23			
	<i>SIDE NOTES AND TABLES</i>	24			
9.0	ENGINEERS MENU	25			
9.1	PIN NUMBER ENTRY	25			
9.2	ENGINEER'S MENU SETTINGS	25			

**Remember *before* installation**

- ↓# **Check that documentation is included.**
- ↓# **Inspect the unit for damage.**
- ↓# **Check serial No. data against your requirements.**
- ↓# **Do not attempt any work on the unit before reading the section on safety.**
- ↓# **The user is responsible for making sure that none of the in-built safety systems are overridden.**
- ↓# **On all chassis units the earth connection should be wired to the panel star point earth.**

## 1.0 SAFETY

### 1.1 In-built safety systems

The TORQ-MASTER 2000 soft starter is fitted as standard with the following safety and protection circuits;

- ↓# Motor overload protection.
- ↓# Motor underload protection.
- ↓# Load monitor.
- ↓# Over temperature.
- ↓# Instantaneous over current trip.
- ↓# Phase loss.
- ↓# Thermistor trip circuit.
- ↓# Limitation on starts per hour.
- ↓# Stalled motor protection.
- ↓# Motor fault.

All chassis mounting soft starters are fitted with an earth connection which must be wired to the control panel star point earth.

The chassis units are to IP2X protection, that is, touchproof by direct contact, although some live parts may be accessible by angled contact.

### 1.2 Safety considerations

This instruction manual is an essential part of the soft start device and must be:

- ↓# Available to competent personnel at all times.
- ↓# Read prior to installation or commissioning.
- ↓# Observed with regard to safety and risk management.

The safety instructions in this manual are described so they can be understood by persons trained in Electrical Engineering. Such personnel should have at their disposal the appropriate tools and testing equipment to enable a safe installation.

Such personnel must obtain any particular or general permits relating to local regulations and meet any requirements regarding:

- ↓# Safety of personnel.
- ↓# Product disposal.
- ↓# Environmental protection.
- ↓# Packaging disposal

**NOTE** The safety measures outlined must remain in force at all times. Should questions or uncertainties arise, please contact your supplier.

### 1.3 User responsibilities

**DANGEROUS VOLTAGES EXIST ON THE SOFT STARTER. ALWAYS REMOVE POWER BEFORE SERVICING**

**DO NOT MEGGER ANY PART OF THE UNIT**

- ↓# It is a legal requirement that soft starters are protected by means of an isolating switch. It is recommended that a lockable isolator or MCCB is installed so that maintenance can be carried out safely.
- ↓# By definition a contactor is not an isolating switch since the coil of the contactor may be inadvertently energised. Do not depend on the circuit being safe if the only isolation is a mains contactor.
- ↓# Never place power factor correction capacitors on the output side of the soft starter, only on the input side.
- ↓# Every soft starter carries a unique serial number which gives information on the power rating of the unit. It is the users responsibility to ensure that the rating is correct for the application.
- ↓# The user must ensure that whenever a **STOP** is called for that the soft starter assumes a **SAFE** operating condition at the end of the stop sequence.
- ↓# The user must ensure no unauthorised person works on the unit.
- ↓# The operator must avoid using any working practises that reduce the safety of the soft starter.

### 1.4 How to use this manual

This instruction manual will in most cases exceed the requirements of the user but it is advisable to read the notes on safety and installation before proceeding further. Each soft starter is set-up and tested at the factory prior to despatch and in the majority of applications the settings need never be altered. Where menu alterations need to be made the user must consult the manual or **Ralspeed's** web site before attempting any changes.

### 1.5 Standards

The unit is manufactured in accordance with the following **EC** standards:-

- ↓# IEC 947-4-2
- ↓# EN 60 204-1 Electrical equipment of machines, part 1, General requirements and VDE 0113
- ↓# EN 50081-2, EMC Emission.
- ↓# EN 50081-1, EMC Emission with by-pass.
- ↓# EN 50082-2, EMC Immunity

## Side notes and tables

### Please use this installation guide

- ↓# Check serial number
- ↓# Position the unit correctly.
- ↓# Never megger any part of the soft starter.
- ↓# Always fit contactor coil suppressors.
- ↓# Keep switching relays close to the PCB.
- ↓# Do not take the +24v outside the control panel or run it with high power high current cables.
- ↓# ALL earths must be connected.
- ↓# In high ambient temperatures it is advisable to force ventilate the control panel.
- ↓# Select the bypass contactor according to the formula opposite (see \*\*)

THIS WARNING LABEL APPEARS ON ALL SOFT STARTERS AND THE SERIAL NUMBER AND OTHER DETAILS ARE LISTED AS SHOWN.

SERIAL No.

MOTOR POWER

MOTOR AMPS

THYRISTORS

## 2.0 Installation

### 2.1 Unit type

Firstly, after unpacking the soft starter the user should check the following:

- ↓# That there is no obvious damage to the unit.
- ↓# Check the serial number label, this will give you information about the kW size and type of soft starter you have purchased. For example, TQM2KB-250 would be a 250kw with a built-in bypass contactor. Whilst a TQM2K-250/B would be a 250kw unit designed for use with a bypass contactor supplied and fitted by the user.
- ↓# It is the user's responsibility to make sure the correct unit has been supplied and that it is fit for the use it was intended.

### 2.2 Location (chassis units)

The standard chassis mounting soft starter is supplied as an IP2X unit designed for installation in industrial switchgear cabinets. The chassis will be supplied with either a built-in bypass contactor or for use with a bypass contactor. In both cases there is minimal heat loss from the starter. It is still good practise, however, to allow 50mm around the unit to allow for some air flow. There is no forced cooling of the heatsink and the only heat generated will be from cables, contactor coils etc. Therefore when mounting the unit in a switchgear cabinet it may be considered the same as a D.O.L. starter. It should be noted that on large power units due to the high running temperature of modern cables and contactor coils forced ventilation of the cubicle is recommended.

### 2.3 Location (complete starter)

The soft starter may also be supplied as a complete unit built into a floor or wall mounting IP54 sheet steel or polyester cabinet. The user will only need to wire in the mains and motor cables, all the rest of the controls will have been pre-wired. The system wiring schematic will describe any special functions or conditions but in general the standard unit will be supplied as a stand alone motor starter.

### 2.4 Cabling

It is not necessary to use shielded control cables but it may be needed if the installation is electrically 'noisy'. Mains and motor cables need not be shielded. When wiring to the soft starter please follow these guidelines:

- ↓# Terminals 1 to 16 are control inputs. Keep the cables short and avoid, where possible, mixing power and control cables.
- ↓# Use tri-rated cable for mains and motor.
- ↓# Terminals 26 to 35 are volt free relay outputs so standard wiring is permissible.
- ↓# Other than the normal restrictions of volt drop on long motor leads there is no limit to the length of cable used between the soft starter and the motor.
- ↓# Due to the switching frequencies and distorted wave shape during ramp up ( or down ) the user must pay particular attention to the tightness of all connections.
- ↓# On larger kilowatt units cable ducting is provided to enable segregation of power and control cables.

### 2.5 Bypass contactors

It is highly recommended that all soft starters are fitted with bypass contactors. Section 2.1 details the two chassis types available. In the case of the TQMB version the contactor has been fitted by the Factory, so the user need only connect mains, motor and control wiring to have a fully operational system. However, in the case of the type TQM\_\_\_/B chassis the user will have to fit the bypass contactor. The connection details are covered in section 11.0 but the rating should follow this formula:

**\*\*FULL LOAD CURRENT OF THE MOTOR + 15%**

And then choose an AC1 rating closest to, but above that figure.

E.g.  $FLC = 100A + 15\% = 115A$  nearest contactor rating is 125A at AC1 so this should be the choice. The reason for the AC1 rating is because of the unique software sequence within the Torq-master unit. Unless specifically overridden the bypass contactor cannot energise until the current has dropped to full load current or less. When a stop command is given and the chosen stop mode is freewheel the software de-energises the BPC and briefly turns the thyristors on so that the contactor does not 'break' any current. Although the bypass contactor is energised and effectively 'shorting out' the thyristors all the protective features such as overload, shearpin, etc. are still fully functional.

#### **IMPORTANT**

**THE BYPASS CONTACTOR MUST HAVE A COIL SUPPRESSOR FITTED**

# Circuit diagrams

NOT FITTED  
IF BYPASS CONTACTOR IS  
BUILT-IN

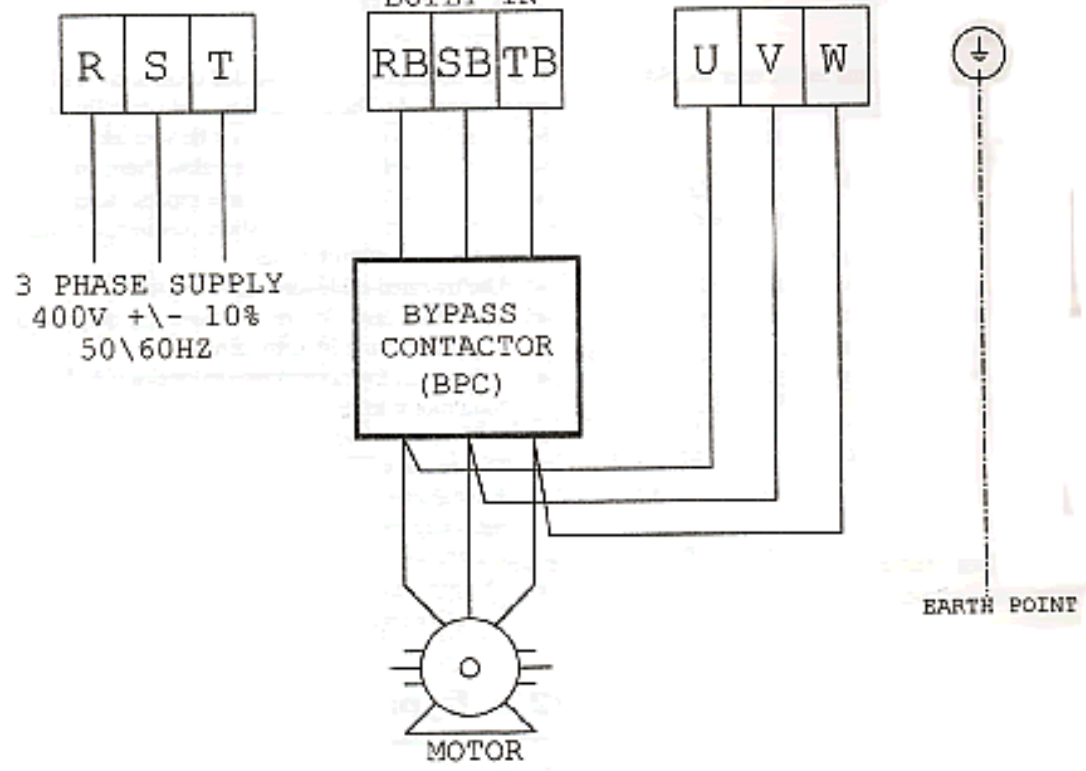

YELLOW = 110V  
BLUE = 220V  
RED = 440V

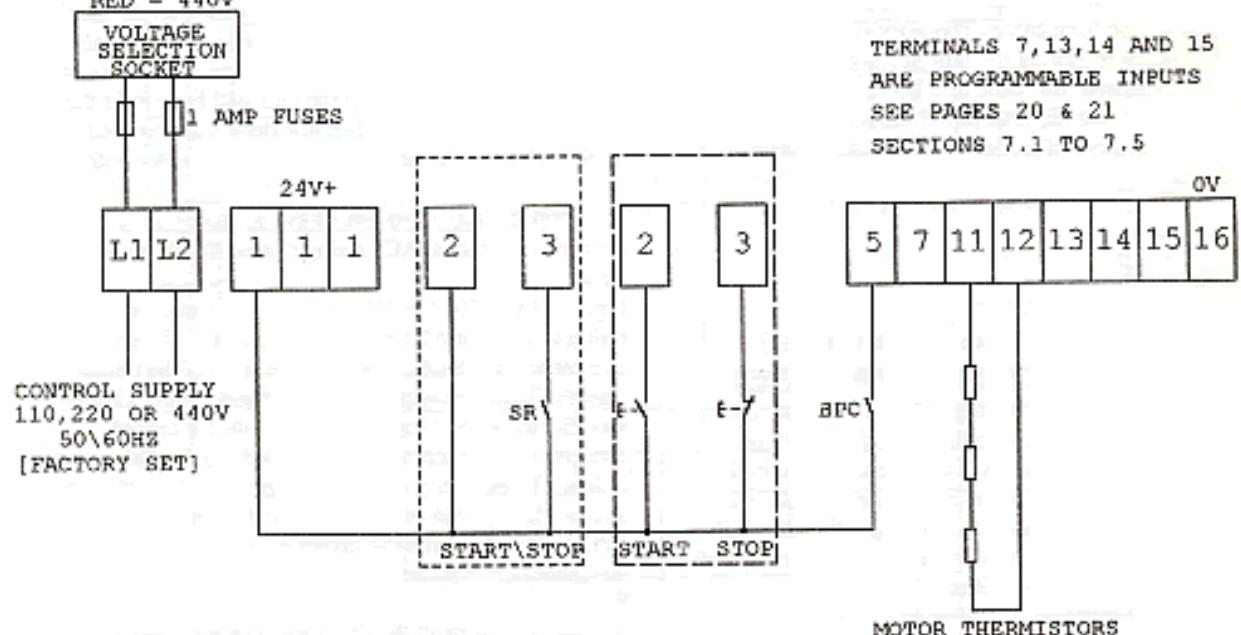

TERMINALS 7, 13, 14 AND 15  
ARE PROGRAMMABLE INPUTS  
SEE PAGES 20 & 21  
SECTIONS 7.1 TO 7.5

SINGLE RELAY CONTACT CONTROL -----  
STOP\START PUSH BUTTONS -----

## 2.0 Installation

### 2.6 Power terminals

R S T

**MAINS SUPPLY 3 PHASE 400V ± 10% 50/60HZ**

RB SB TB

**OUTPUT 3 PHASE TO THE LINE SIDE OF THE BYPASS CONTACTOR (THESE TERMINALS ARE NOT FITTED IF THE BYPASS CONTACTOR IS BUILT-IN)**

U V W

**OUTPUT 3 PHASE TO THE MOTOR**

### 2.7 Control terminals

**Terminals L1 & L2**

These terminals are the input for the electronics power supply input. This input can be 110v, 220v or 440v 50/60hz. This is a factory set input based on customer requirements and is always marked. On 'board' fusing and voltage selection are under the metal PCB cover. On units with a built-in bypass contactors L2 and L2 are provided as a separate connection.

**Terminal 1,1,1, (+ 24v)**

There are 3 number 1 terminals in order to avoid doubling up cables. The No 1 terminal is a 24v+ source and is used for all control applications.

**TOTAL POWER DRAWN SHOULD NOT EXCEED 300mA AND SHOULD NEVER BE TAKEN OUTSIDE THE PANEL**

**Terminal 2 (Start)**

This is the input start command and should be used with a normally open momentary push button.

**THIS IS A LATCHED INPUT**

**Terminal 3 (Stop)**

Terminal 3 is the input stop command and should be used with a normally closed momentary push button.

**FOR RELAY CONTROL OF START/STOP — SEE OPPOSITE**

**Terminal 5 (Bypass)**

If a bypass contactor is fitted terminal 5 is used to confirm that the contactor has energised.

**SEE DIAGRAM OPPOSITE FOR DETAILS**

**Terminal 7 (Program 1)**  
[see page 20\21 section 7.4, 7.5]

This terminal is the first of the programmable inputs. Depending on the program selected either a N\O or N\C contact will be needed to execute the program function.

**Terminal 11 & 12 (Thermistor I\P)**

These terminals are dedicated for the use of PTC motor thermistors. Circuit will accept 3 x PTC probes in series of approx 250 each. The circuit trips at 2.6K . The circuit voltage is 5v+

**Terminal 13,14 & 15 (Prog' I\Ps)**  
[see page 20\21 section 7.4, 7.5]

These terminals are the three remaining programmable inputs and are the same as program 1

**Terminal 16 (zero volts)**

This is the zero volt connection and can be used to provide a 'common' for relays or external voltage inputs.

# Circuit diagrams

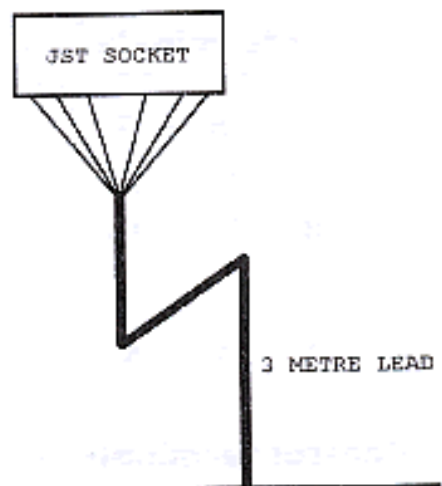
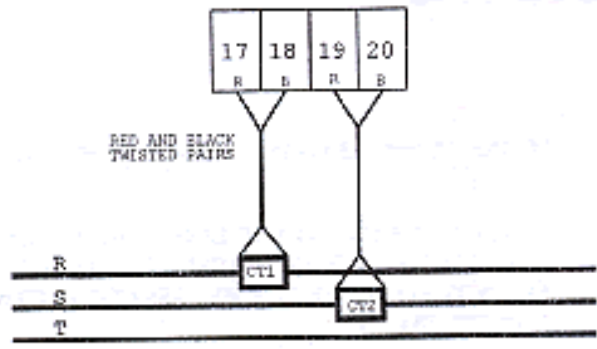

FOR WIRING DETAILS ON PROGRAMMABLE RELAYS  
SEE PAGES 22 & 23 SECTION 8.1 TO 8.3

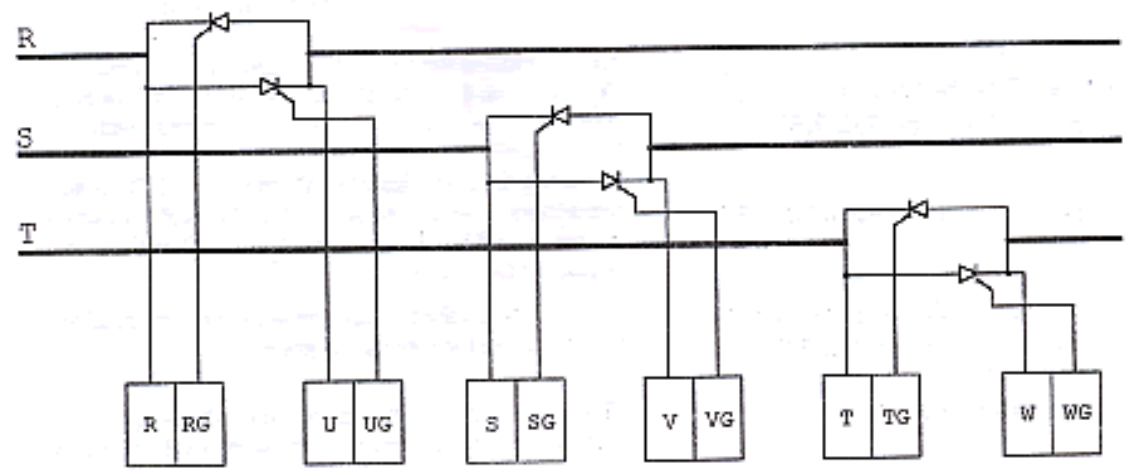
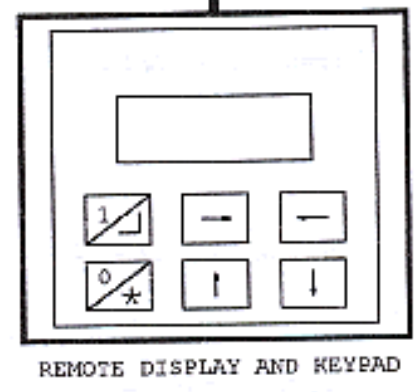
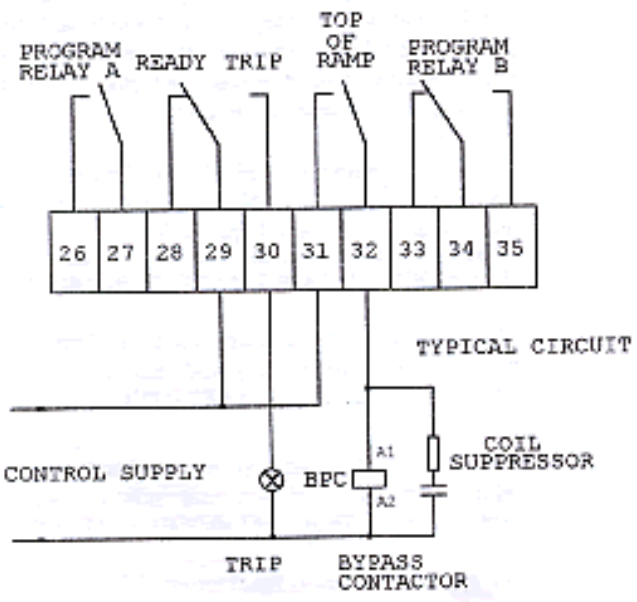

## 2.0 Installation – cont

### 2.8 C.T. terminals

**Terminals 17,18,19 & 20**

These four terminals are the input for the current transformers.

**THEY ARE NEARLY ALWAYS PRE-WIRED**

### 2.9 J.S.T Socket

Although not terminals the J.S.T. socket is positioned in the terminal block line and is used to connect to the remote keypad. (supplied as standard with a 3mtr lead)

### 2.10 Relay terminals

**Terminals 26 & 27 (Relay A)**

Relay **A** on terminals 26 & 27 is a single pole single throw programmable relay The contacts are rated at 10A @ 400v.

**ONLY ONE FUNCTION CAN BE ASSIGNED AT ONE TIME**

**Terminals 28,29 & 30 (Ready\Trip)**

This is a dedicated relay and is not programmable. It's function is to provide a 'READY' signal with power to L1 & L2 and no fault. Also a 'TRIP' signal if the soft starter detects a fault.

**Terminals 31 & 32 (Top of Ramp)**

The top of ramp relay is used to energise a bypass contactor and is rated at 10A 400v.

**Terminals 33,34 & 35 (Relay B)**

This is the second programmable relay and is a single pole changeover type again rated at 10A 400v.

### 2.11 Gate\Cathode terminals

**Terminals R, RG U,UG**

R = cathode red phase input RG = gate, red phase.  
U = cathode red phase output UG = gate, red phase

**Terminals S,SG V,VG**

S= cathode yellow phase input. SG = gate, yellow phase.  
V= cathode yellow phase output SG = gate, yellow phase

**Terminals T,TG W,WG**

T = cathode blue phase input TG = gate, blue phase.  
W = cathode blue phase output WG = gate, blue phase

**NOTE**  
**ALL CATHODE LEADS ARE RED**  
**ALL GATE LEADS ARE EITHER YELLOW OR WHITE**

Keypad guides

- ↓# The LCD display is 2 line 16 character backlit type.
- ↓# In case of a fault or trip the display will give the user a readout of the type of fault.
- ↓# The information screens cannot be accessed during ramp-up or ramp-down.
- ↓# The remote keypad and the main keypad have the same layout and the buttons function in the same way.

Menu listings

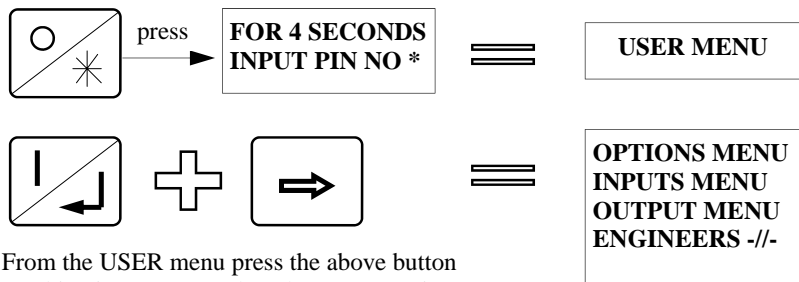

From the USER menu press the above button combination to access the other menu settings

\* The standard PIN No is **17**. Consult your supplier for instructions on how to change this number

Holding the **ENTER** button down and pressing the forward arrow button will take the user through the rest of the menu headings. Pressing the **stop\reset** button at any time will allow an **EXIT** from the menu and the screen will give instructions on how to save the changes and to return to the ready to start screen.

## 3.0 Keypad and display

### 3.1 Layout

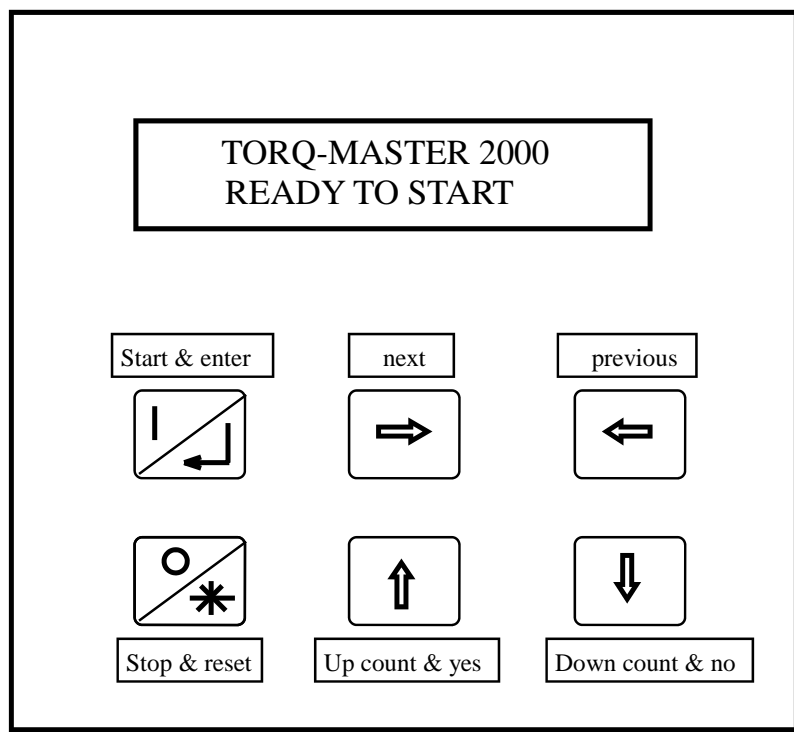

### 3.2 How to use the keypad

To enter the menu, hold down the 0\\* button for 4 seconds. The display will ask the user to enter a PIN No. This has been set at the Factory to 17 use the 'up count' button until 17 appears in the display. Press the **NEXT** key and the display will show the **USER MENU** and ask the user to enter the full load current of the motor. Under normal circumstances this value will have been set in the menu during final testing at the Factory. Using the **NEXT** button will scroll through the menu and enable the user to alter types of ramp i.e. voltage or current or to choose overload curves etc. To alter a setting in any menu the **ARROW** buttons should be used as described The full list of available features in the **BASIC USER MENU** is listed on page 15

After making the changes in any of the menus if the user presses the **STOP\RESET** button the LCD display will give the instruction to press the button again to exit the menus and save the changes. To access the other menus from the **USER** menu hold down the **Start\enter** key and press the **NEXT** key – one press shows **OPTIONS** two shows **INPUTS** three shows **OUTPUTS** four shows **ENGINEERS**

**Side notes and tables  
For start-up screens**

**Start-up and information screens**

- ↓# **READY TO START** means the unit is waiting for a start command.
- ↓# **To enter the menu HOLD THE STOP/RESET BUTTON DOWN FOR FOUR SECONDS AND THEN ENTER THE PIN NUMBER**
- ↓# **Holding down the START/RESET button and pressing the NEXT key will take the user from menu heading to menu heading.**
- ↓# **Using the NEXT button only will display the information screens.**
- ↓# **After entering the event log the screen will show the 'last' event. Use the PREV button to 'backtrack' through the log.**

## 4.0 Screens

### 4.1 Start-up screens

TORQ-MASTER 2000  
READY TO START

TORQ-MASTER 2000  
NO THREE PHASE

TORQ-MASTER 2000  
NO MOTOR

TORQ-MASTER 2000  
EMERGENCY STOP

### Explanation

With power to L1 and L2 the first screen will show that the soft starter is ready to start and is waiting for a start command.

When the ready to start screen is shown and a start command is given the unit will check to see if the three phase mains is available, if not, the screen shown opposite will appear.

If a start command is given and the three phase is present but the motor has two or more connections missing the screen will show **NO MOTOR**.

When emergency stop is chosen in the programmable inputs menu, and is actuated, even when a start is called for and mains and motor are connected the unit will not respond until the EM stop circuit is restored to normal.

From any of the above screens or at any time the motor is running the user can choose to view the information screens as shown below by pressing the NEXT button.

### 4.2 Information screens

AMBIENT TEMP 30C  
■■■■■■■■■■ min

MOT CURRENT 000%  
■■■■■■■■■■ min

DATE 21\08\00  
TIME 14:58:25

SERVICE : EXPIRED  
8,500h 15h

OPEN EVENT LOG  
PRESS ENTER

E.01 NO MOTOR  
14:35 18:08:00

This screen shows the user the ambient temperature in the area around the soft starter unit. This should not be beyond 45\50C. Temperatures above this figure can result in the soft starter malfunctioning.

The motor current bar graph gives the user a view of the motor amps and its percentage value in comparison with the full load setting. (only displays with motor running)

The user can display the current time and date by accessing this screen. Any changes can be made in the **Engineers menu**.

Service time for some machines is very important and this screen shows the user the time period between services and the elapsed time. A programmable relay can be configured to give an output signal when the service time is reached.

The unique software package within the soft starter has the ability to log the last 1000 events. This is a rolling log with battery back-up so that the unit can be interrogated at any time. The log will show the time and date of the event and also the event itself.

# O\L and starting graphs

TYPICAL OPERATING TIME CHARACTERISTICS FROM COLD START

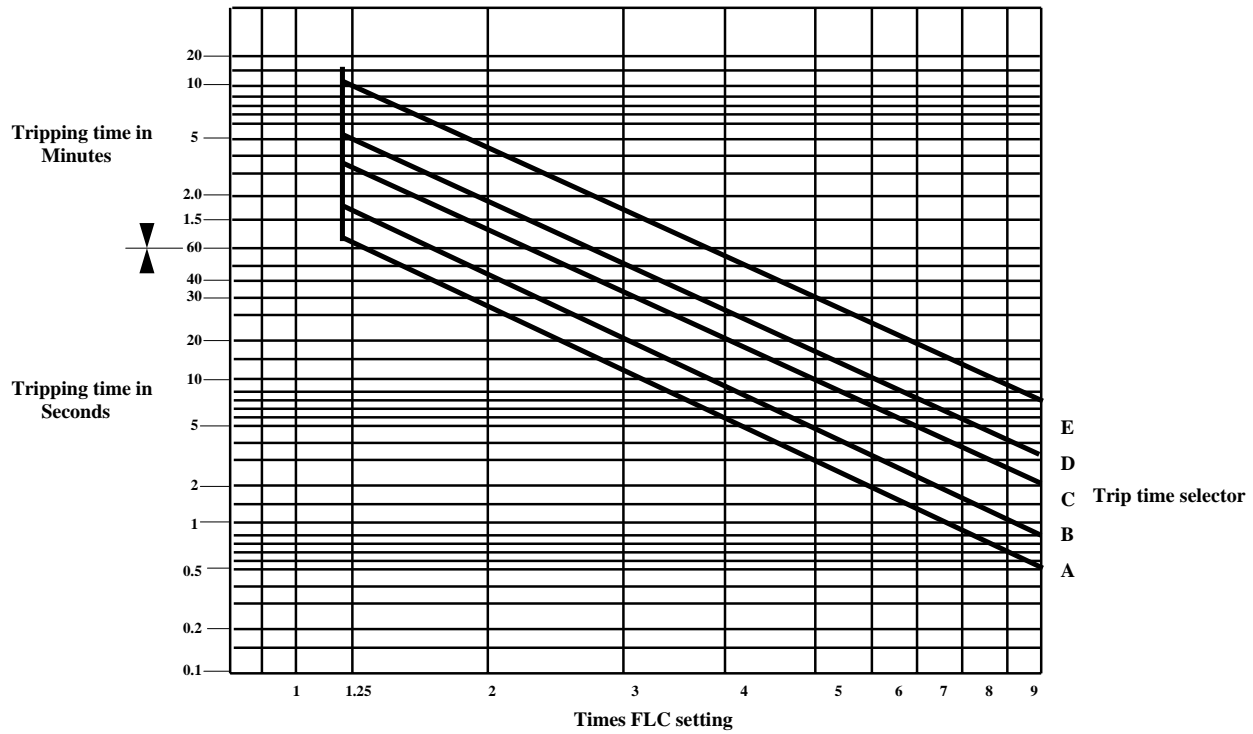

## Maximums & Minimums

Kick start	0.2 to 2secs
Level	70% voltage
Ramp-up	1 to 240secs
Pedestal	25 to 70% V
Target	40 to 100% V
Ramp down	1 to 240secs
Initial	100 to 40% V
Final	20 to 50% V

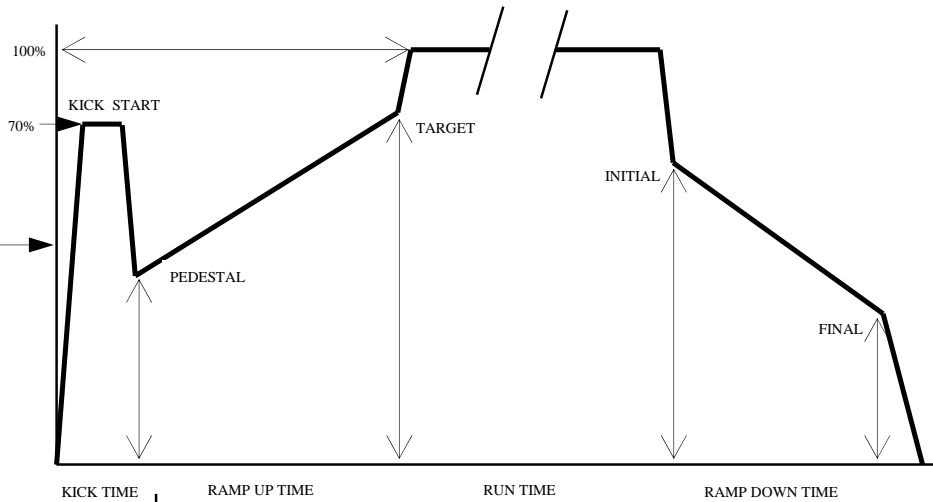

Time to limit	1 to 10 secs
Current limit	100 to 600%
Time at limit	1 to 60 secs

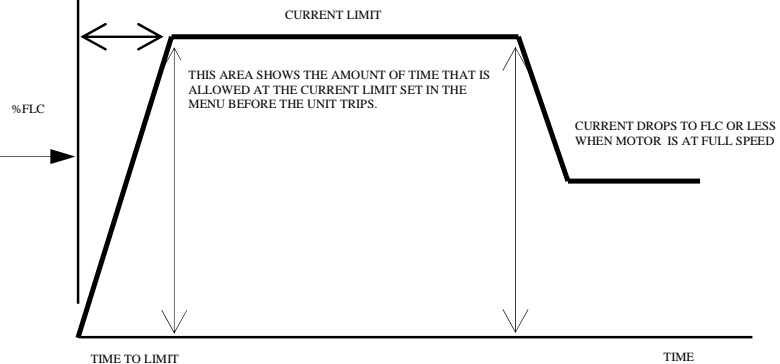

## 5.0 Screens - User menu

TO ENTER THE USER MENU; HOLD DOWN THE STOP/RESET BUTTON FOR 4 SECONDS AND ENTER THE PIN NO (FACTORY SET TO 17)

### Screen

### Explanation

#### 5.1 Motor protection

TORQ-MASTER 2000  
SET FLC 0000A

The user should enter the full load or nameplate current of the motor to be controlled. It is important to enter the correct figure or the overload and other protective devices will not operate correctly.

next

CHOOSE O/L CURVE  
A B C D E

There is a choice of five different overload curves. This enables the user to match the overload trip point to the load application. Please note these are cold start curves and every 'start' will reduce the tripping times.

**SEE OVERLOAD CURVES OPPOSITE**

#### 5.2 Motor start up

next

RAMP TYPE  
VOLTAGE

After setting the overload curve, pressing the next button will ask the user to choose either a voltage, or a current control ramp-up.

**SEE VOLTAGE RAMP CURVE OPPOSITE**

next

RAMP UP 10S  
KICK TIME 0000ms

If the voltage control ramp is chosen the user will be asked to set the ramp-up time. This is normally Factory set to 10 seconds (max = 240s). The second item in this screen is the kick start facility which gives the motor an instantaneous 70% voltage boost for up to 2 seconds in 200ms steps.

next

PEDESTAL 40%  
TARGET 100%

The settings in this screen enable the user to adjust the starting torque and set the final 'run out' voltage. The pedestal is normally pre-set to 40% and under most circumstances should not be altered. The target voltage setting is used to give more linear acceleration for some applications, although it is normally set to 100%

OR

**SEE CURRENT CONTROL CURVE OPPOSITE**

RAMP TYPE  
CURRENT

next

RAMP UP 00S  
I LIMIT 000%

The first question in this screen is RAMP UP and the user must input a value between 1 and 10 seconds which determines how long it will take for the current to rise to the limit. I LIMIT asks the user to set the multiple of full load current that will be the maximum during the ramp to full speed.

next

TIME LIMIT FOR  
I RAMP 00S

In this screen the user must set the length of time allowed at the current limit before the unit trips. The user should try to set this value in order to co-ordinate with existing fuses or breakers

# Soft stop and brake stop graphs

**Maximums & Minimums**

Ramp down	1 to 240secs
Initial	100 to 40% V
Final	20 to 50% V

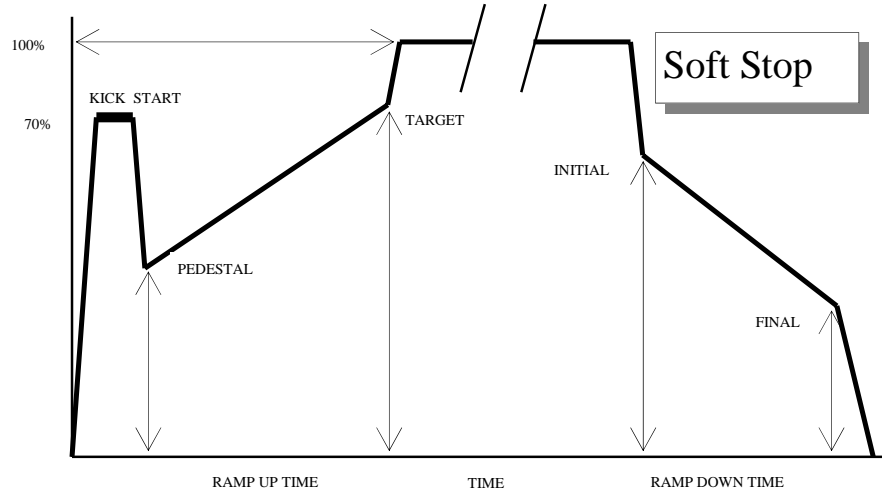

**Soft Stop**

Ramp time	1 to 20 secs
Brake volts	10 to 100%
Brake time	1 to 240 secs

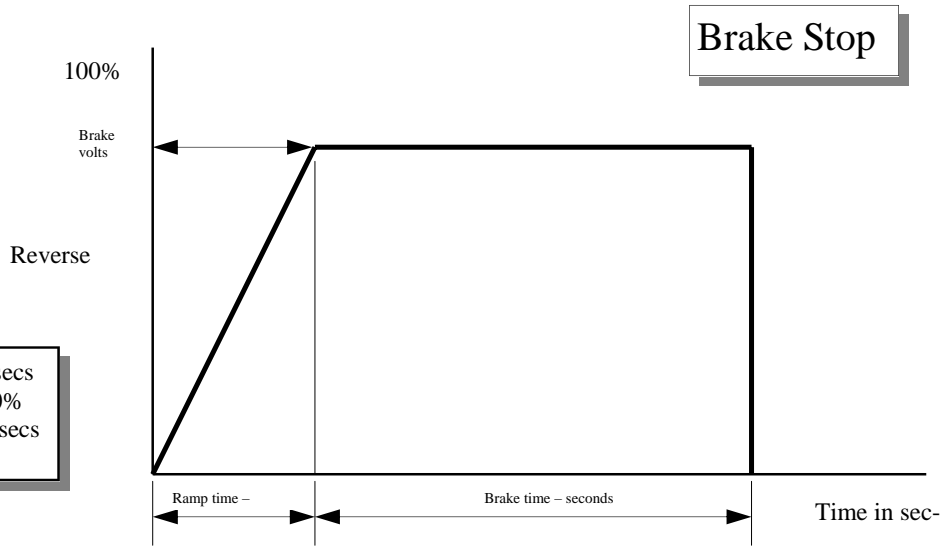

**Brake Stop**

## 5.0 Screens - User menu – continued

### Screen

### Explanation

#### 5.3 Control

START / STOP  
TERMINAL/KEYPAD

Within the user menu the stop/start control can be configured to be either via the terminals or the keypad. The latter choice would only be used when the remote panel mounting keypad is used.

#### 5.4 Stop modes

STOP MODE S:B:F  
RAMP 000S

The user has a choice of three independent stop modes  
 ↓# Soft stop (S)  
 ↓# Brake stop (B)  
 ↓# Freewheel stop (F)  
 The type of stop can be changed by using the program inputs menu.  
 The ramp setting is in seconds and determines the time between INITIAL & FINAL values.

next

INITIAL 00%  
FINAL 00%

If soft stop is chosen the user needs to input settings to control the ramp down. The soft stop is used mainly in pumping systems to avoid 'water hammer' and damage to the piping. The INITIAL value is a percentage of full volts and should be set so that the speed of the motor is affected immediately. The FINAL value is also a percentage of full volts and is the natural 'stall' point of the motor/load.

next

BRAKE VOLTS 00%  
BRAKE TIME 00S

The brake stop option is of the 'reverse plug' type and requires reversing contactors at the front end of the soft starter. The three adjustments the user will have to enter are:  
 ↓# RAMP - this is in seconds and is the length of time it will take for the voltage to reach the BRAKE VOLTS setting.  
 ↓# BRAKE VOLTS – this is a percentage of the mains voltage and is dependant on how severe the user requires the braking to be.  
 ↓# BRAKE TIME – The brake time setting should be set to reverse brake the motor to a stop but not to allow it to go into reverse.

STOP MODE F  
RAMP 000S

If FREEWHEEL stop is chosen the motor will run down under its own inertia when a stop command is given.

**Options menu  
Side notes and tables**

**Some points to remember**

- ↓# Always fit coil suppressors to the by-pass contactor and also to the main contactor (if fitted)
- ↓# If the time for the underload trip is set to zero the unit will trip immediately after top of ramp is reached and the current is at the set point.
- ↓# Shearpin trip has a maximum setting of 800% of FLC. This setting can be used to co-ordinate with fuses and breakers.
- ↓# The user should only operate the auto reset/restart providing there is no safety risk in automatically restarting the motor.
- ↓# The overload pre-alarm is designed to act as a warning that the motor is running at a higher current than is normal.

**IT IS HIGHLY RECOMMENDED THAT A BYPASS CONTACTOR IS USED FOR EVERY APPLICATION**

## 6.0 Screens - Options menu

Screen	Explanation
6.1 TORQ-MASTER 2000 BYPASS CONT    Y/N	The user has the choice in the OPTIONS menu to input various settings to 'tailor' the starter to the application. The first setting is BYPASS CONTACTOR. It is highly recommended that this option is always set at YES. <b>Normally this is set at the factory</b>
6.2            next THERMISTOR    Y\N	Terminals 11 and 12 are the thermistor trip input but the user has to 'enable' the function in this menu heading.
6.3            next U/LOAD        00% TRIP IN       00 MIN	The underload trip option allows the user to set a lower than full load current value as an 'underload' trip point at which the soft starter will stop after the time set.
6.4            next SHEARPIN      Y/N LEVEL         000%	The shearpin trip is again a percentage of full load current. When the software detects a rise in current to the level set, the starter trips immediately.
6.5            next AUTO RESET    Y/N AUTO START   1:2:3	Automatic reset is an option choice for the user to enable the soft starter to automatically reset and restart up to three times before finally locking out. This reset only operates during the ramp-up period.
6.6            next O/L PRE ALARM Y/N SET LEVEL    00%FLC	The overload pre-alarm acts similar to a load monitor and allows the user to set a value of current (less than full load current) at which the unit will give an alarm output if a programmable relay is assigned to it, see pages 22 & 23. The pre-alarm circuit is not designed to trip the starter unless the programmable relay is used but the screen will flash when the pre-alarm condition is detected.

# Circuit diagrams

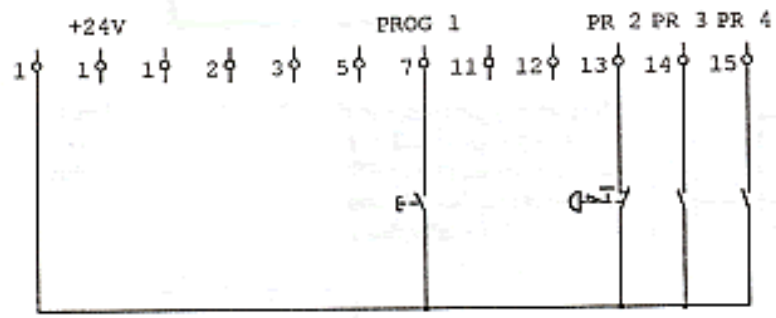

**TYPICAL SYSTEM**

TER.7	INCH
TER.13	EM. STOP
TER.14	START DELAY
TER.15	EXT TRIP 1

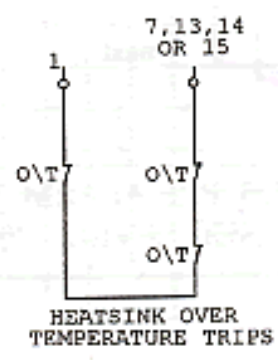
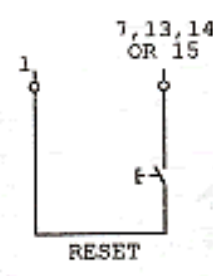
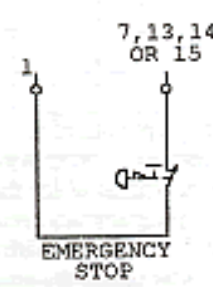
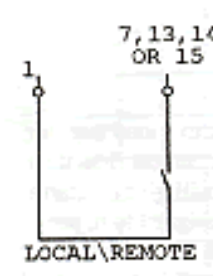
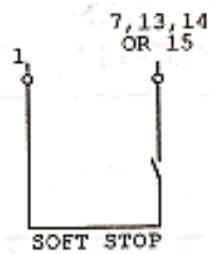
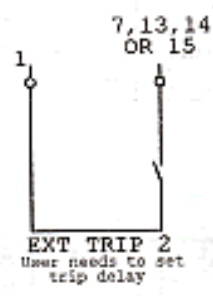
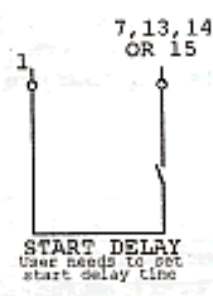
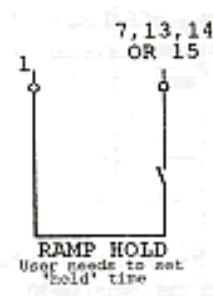
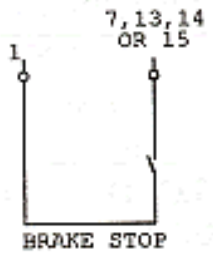
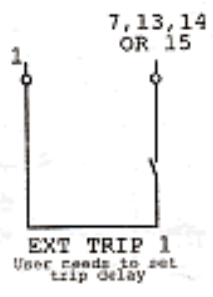
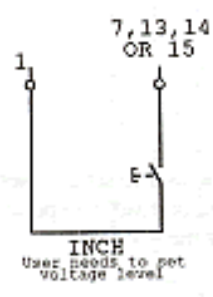

## 7.0 Programmable inputs menu

### Screen

### Explanation

7.1

```
INPUT PROG NUM 1
TERMINAL       7
```

When the user first enters this menu the programmable input and terminal numbers are shown.

7.2

```
INPUT PROG NUM 2
TERMINAL       13
```

There are four programmable inputs on terminals 7,13,14 and 15. The user can choose an input and then assign ***one*** program to that terminal. The program inputs are listed below and it enables the user to tailor the soft starter to a particular application.

7.3

```
INPUT PROG NUM 3
TERMINAL       14
```

For example, if the user needed a 'soft' inch facility for say, positioning purposes, an input would be chosen and inch would be assigned to that input. Therefore whenever the inch button was pressed the voltage would rise to the inch level setting.

**ONLY ONE INPUT PER PROGRAM**

7.4

```
INPUT PROG NUM 4
TERMINAL       15
```

The table shown lists the available program inputs.

- ↓# INCH Soft inch, can be used for positioning, the user needs to set the voltage level.
- ↓# RESET RUN HOURS A momentary contact on the program input will reset the hour counter to zero.
- ↓# EXT TRIP 1 This is a delay on de-energisation timer. The user will have to set the time required.
- ↓# BRAKE STOP Under normal conditions the stop mode is set in the user menu but using this program input the brake stop mode can be turned on and off to suit operational requirements.
- ↓# RAMP HOLD This allows the user to halt the ramp-up for a set period.
- ↓# START DELAY This allows the user to set a delay after receiving a start command.
- ↓# EXT TRIP 2 Delay on energisation timer.
- ↓# SOFT STOP Allows the soft stop function to be switched on and off with a program input.
- ↓# LOCAL\REMOTE This program input switches the stop\start control from keypad to terminals.
- ↓# EM STOP For use with an emergency stop button or relay. Requires a N\C contact to prevent tripping.
- ↓# RESET Once set, this program input will reset any fault within the soft starter. Needs a momentary N\O contact.
- ↓# H\S OVER TEMP If over temperature trips are fitted to the thyristor stack this input can be set to monitor the trips.

### 7.5 Program inputs

INCH	Y\N
LEVEL (min = 25%, max = 80%)	00% V
RESET RUN HOURS	Y\N
EXT TRIP 1	Y\N
TRIP DELAY	00S
BRAKE STOP	Y\N
RAMP HOLD	Y\N
HOLD TIME	00S
START DELAY	Y\N
DELAY TIME	00S
EXT TRIP 2	Y\N
TRIP DELAY	00S
SOFT STOP	Y\N
LOCAL\REMOTE	Y\N
EM STOP	Y\N
RESET	Y\N
H\S OVER TEMP	Y\N

## Circuit diagrams

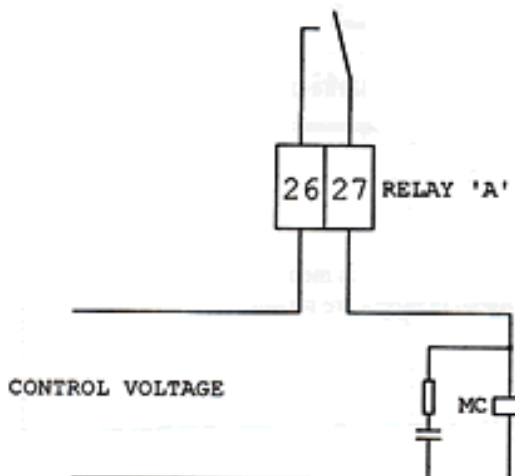

NOTES

This circuit shows the user how to wire in a main contactor and control it from a programmable relay. In this case relay 'A' has been chosen and whenever a start command is given the relay will close and energise the main contactor

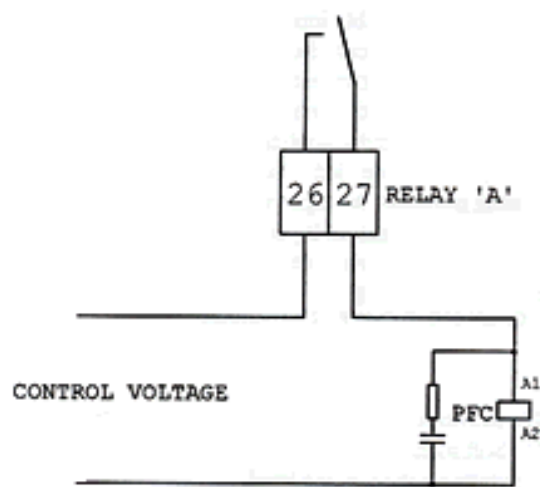

NOTES

This circuit shows the user how to wire in a power factor contactor and control it from a programmable relay. In this case relay 'A' has been chosen and whenever a start command is given relay 'A' will energise 500ms after the bypass contactor has energised and will de-energise 500ms before the bypass contactor when a stop command is given

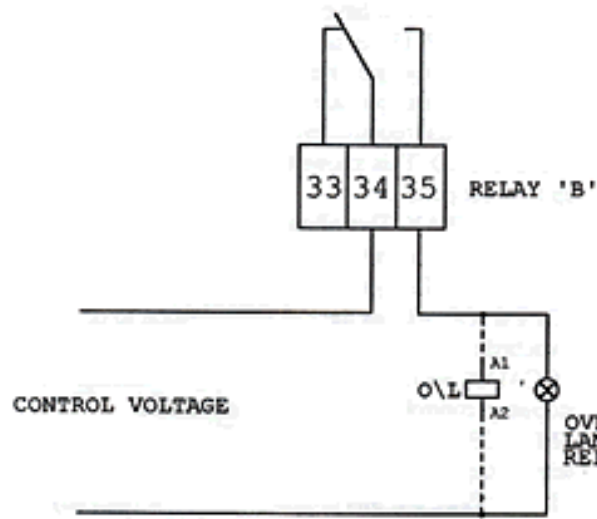

NOTES

In this circuit relay 'B' is dedicated to motor overload fault. If an overload is detected the relay will changeover and illuminate the lamp or drive a slave relay.

## 8.0 Programmable output menu

### 8.1 programmable relay A

OUTPUT PROG A  
RELAY A T 26 & 27

This is the first of two programmable relays and the user may choose to assign any one of the functions listed below to this relay.

### 8.2 programmable relay B

OUTPUT PROG B  
RELAY B T 33,34 & 35

This is the second of two programmable relays and the user may choose to assign any one of the functions listed below to this relay.

### 8.3 programmable functions

OUTPUT PROG NUM \_\_\_\_

OVERLOAD  
UNDERLOAD  
THERMISTOR  
SERVICE OVER  
PHASE FAULT  
FIRING FAULT  
EXTERNAL TRIP 1  
EXTERNAL TRIP 2  
O/L PRE-ALARM  
MOTOR RUNNING  
SHEARPIN TRIP  
TO MANY STARTS  
BRAKE TIME OVER  
TOP OF RAMP  
POWER FACTOR

The user has to choose the programmable relay to be used and assign a function to it. Once a relay has had a function assigned the menu structure does not allow any more functions to be accessed. The user must cancel the action assigned before the menu will show the other options available.

The relays are all rated at 10amps AC1 with a voltage withstand of 400v, 50\60hz. The relays can switch DC voltages but the switching current is reduced to 3amps. If large currents need to be switched it is recommended that a slave relay is used.

POWER FACTOR is a unique and special setting that enables the user to energise a contactor from a programmable relay so that the power factor capacitors are only charged or discharged whilst the bypass contactor is energised.

**REMEMBER**

**ONCE A FUNCTION HAS BEEN ASSIGNED TO A RELAY NO OTHER FUNCTIONS ARE AVAILABLE**

## Side notes and tables

**Please note that the Engineers menu is accessed via a PIN No. and the settings can disconnect safety systems therefore:**

- ↓# Do not leave the overload permanently disconnected.
- ↓# Do not change the CT ratio without contacting the Factory.
- ↓# Do not alter the terminal 5 delay without understanding the consequences of such an action.

**THERE ARE MORE SETTING IN THE ENGINEERS MENU THAN ARE LISTED BUT THE USER SHOULD NOT ALTER ANY OF THESE WITHOUT CONSULTING YOUR SUPPLIER**

## 9.0 Engineers menu

### Screen

### Explanation

#### 9.1 Entering pin number

```
TORQ-MASTER2000
ENTER PIN NO  ____
```

Although all the previous menus have been designed for full user access the ENGINEERS MENU can only be opened by entering a second PIN number.

**THE OPTIONS LISTED IN THIS MENU SHOULD ONLY BE ALTERED BY AUTHORISED PERSONNEL**

#### 9.2 Engineers menu settings

```
SET PIN MAIN  17
SET PIN ENGR  19
```

The PIN numbers are set at the factory and should only be altered with the permission of RALSPEED.

```
CT TRANS      ____A
O/L IN RAMP   Y\N
```

The current transformer ratio is set at the Factory. There are some applications where the overload, even with the slowest trip setting, will still trip during ramp up. Using this facility the overload can be disabled during the ramp up.

```
DUTY CYCLE
STARTS PER HR  00
```

The standard duty cycle is 10\12 starts per hour. This is for units up to 186kw. Above that 5\6 per hour is normal. If the menu is set to zero there will be no restrictions to the number of starts per hour.

```
HOURS RUN
      15
```

This screen tells the user how many hours the soft starter has been running.

**THIS COUNTER IS NOT RESETTABLE**

```
TIME      00:00:00
DATE      00:00:00
```

The time and date can be altered in this screen

```
SERVICE      8750H
T 5 DELAY    00S
```

The first part of this screen asks the user if there is to be a service interval, and if so how many hours between services.

The second part of this screen is designed to allow a 'ride through' when the voltage 'dips'. This will prevent the unit tripping.

```
ENABLE ADJUST Y\N
CURRENT READING
```

If the current reading on the LCD screen does not agree with other independent readings the current readout can be altered whilst the motor is running by enabling the current adjust set up. Once the change has been done the user must enter and exit the menus to set the change.

```
PHASE SETTING Y\N
PHASE CHECKING Y\N
```

If the user requires the soft starter to be phase rotation sensitive then both questions should be set to YES. After the next START the unit will have logged the phase sequence and the user will have to enter and exit the menu to set the change. Thereafter the phase sequence will be checked on every start up.

# 10.0 Trouble shooting flow chart

The TORQ-MASTER 2000 has been designed so that the two line sixteen character display gives the user information on the running and fault status of the unit. The following flow charts will allow the user to rectify problems when the display does not give any indication of the problem or is waiting for start command or other inputs from the external control system. This flow chart also helps the user to interpret some of the specialised messages.

## 10.1 The soft starter does not run

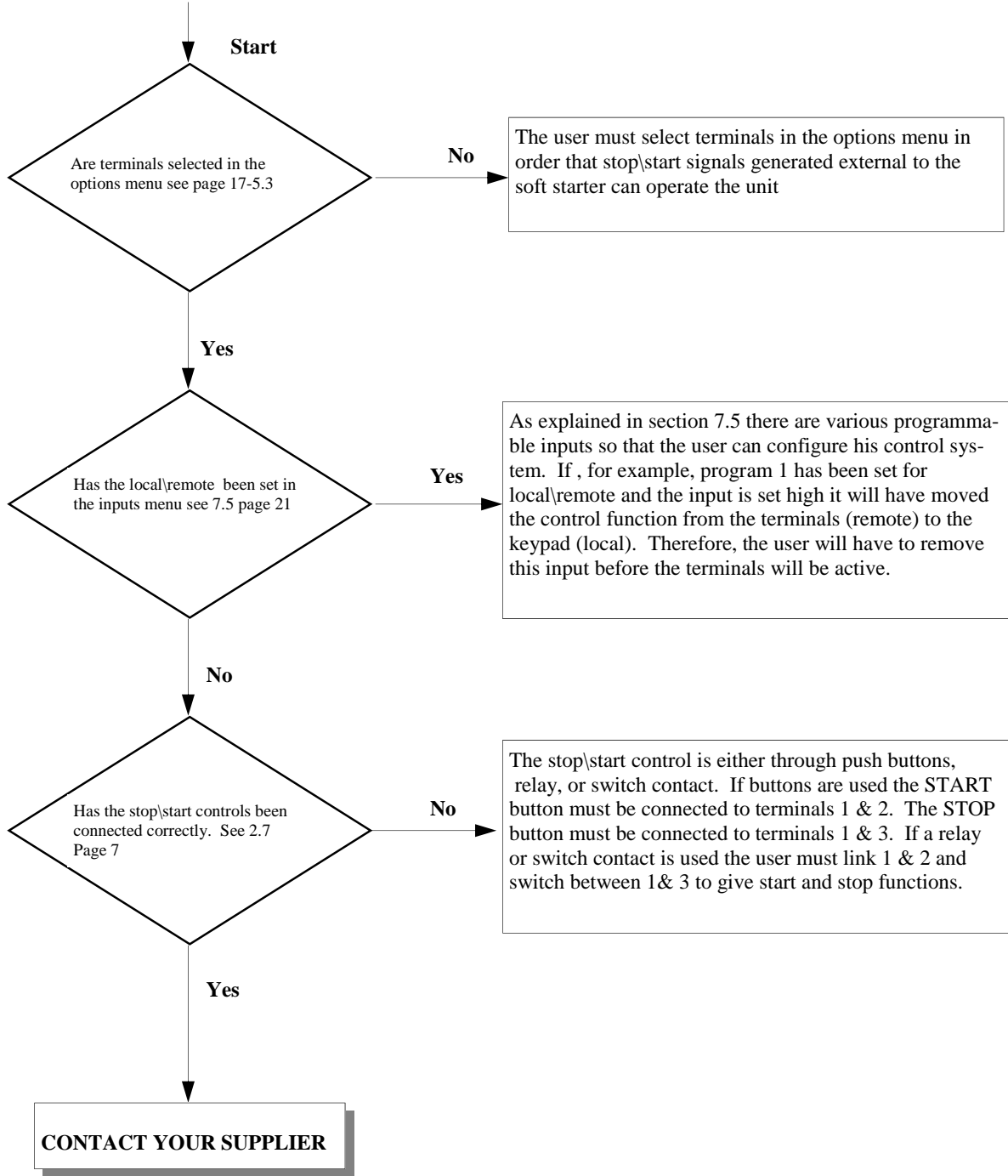

# 10.0 Trouble shooting - continued

## 10.2 The soft starter trips on firing fault.

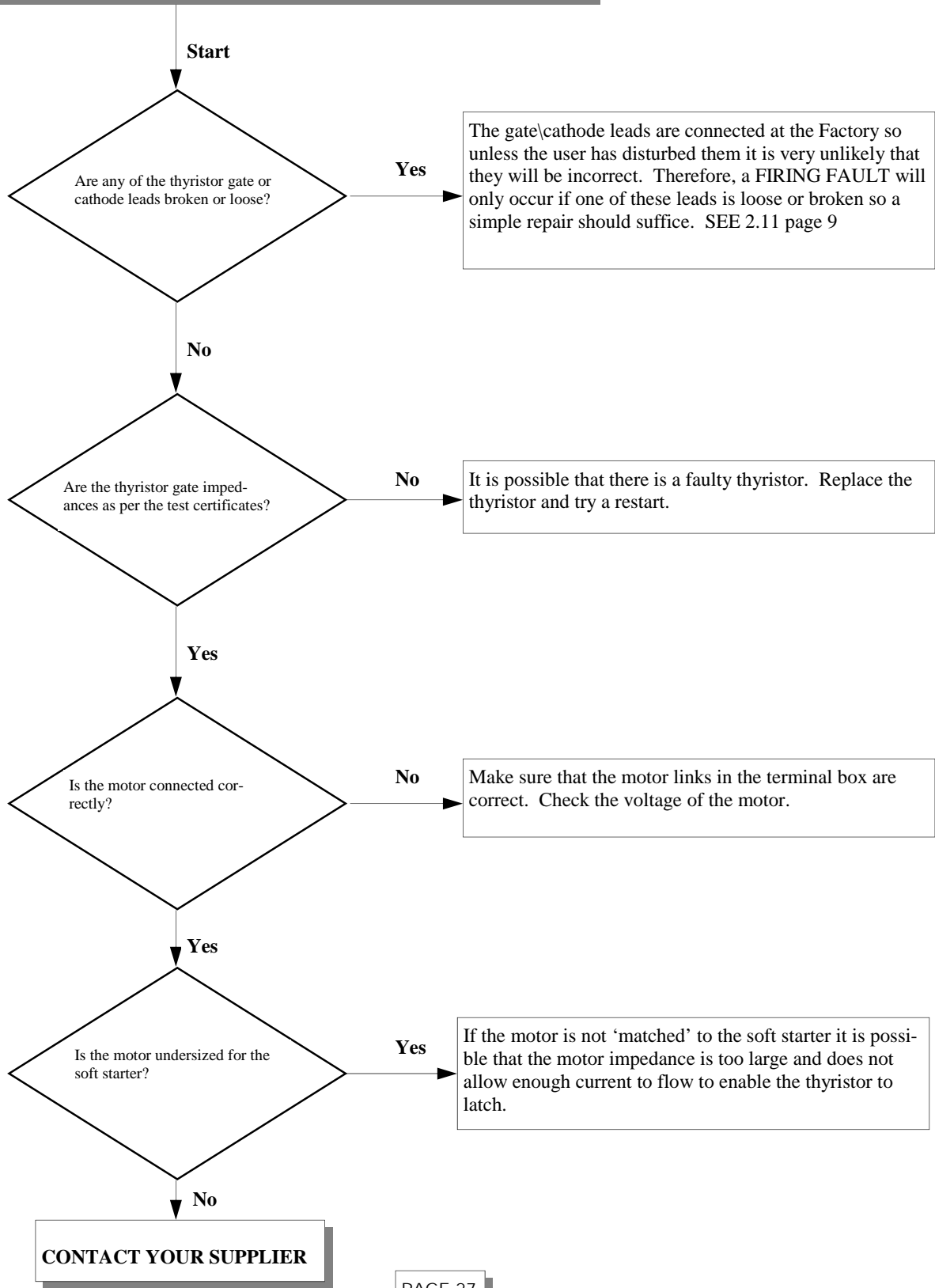

## 10.0 Trouble shooting - continued

### 10.3 The soft starter trips on overload fault.

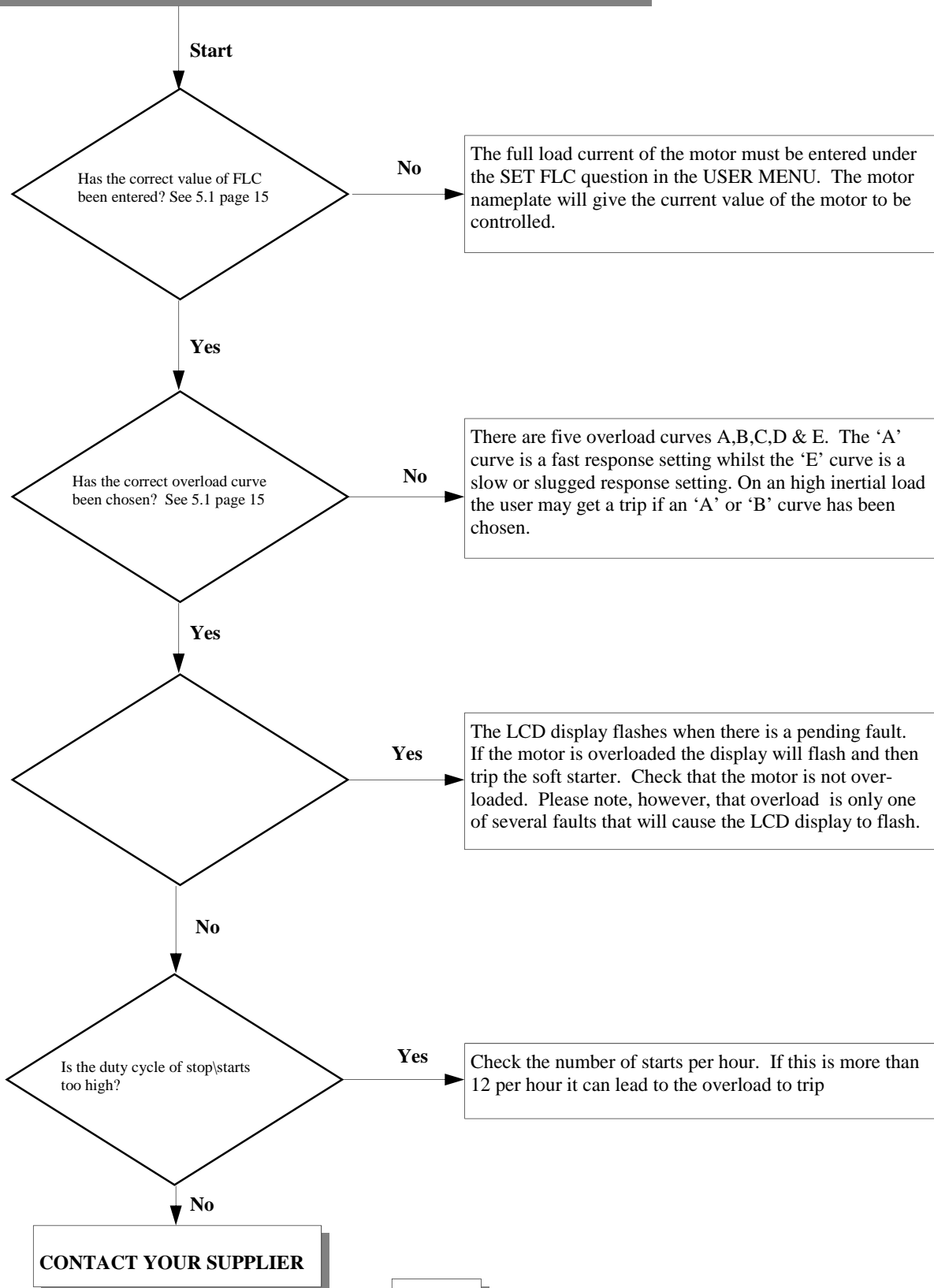

## 10.0 Trouble shooting - continued

### 10.4 The soft starter trips on shearpin fault.

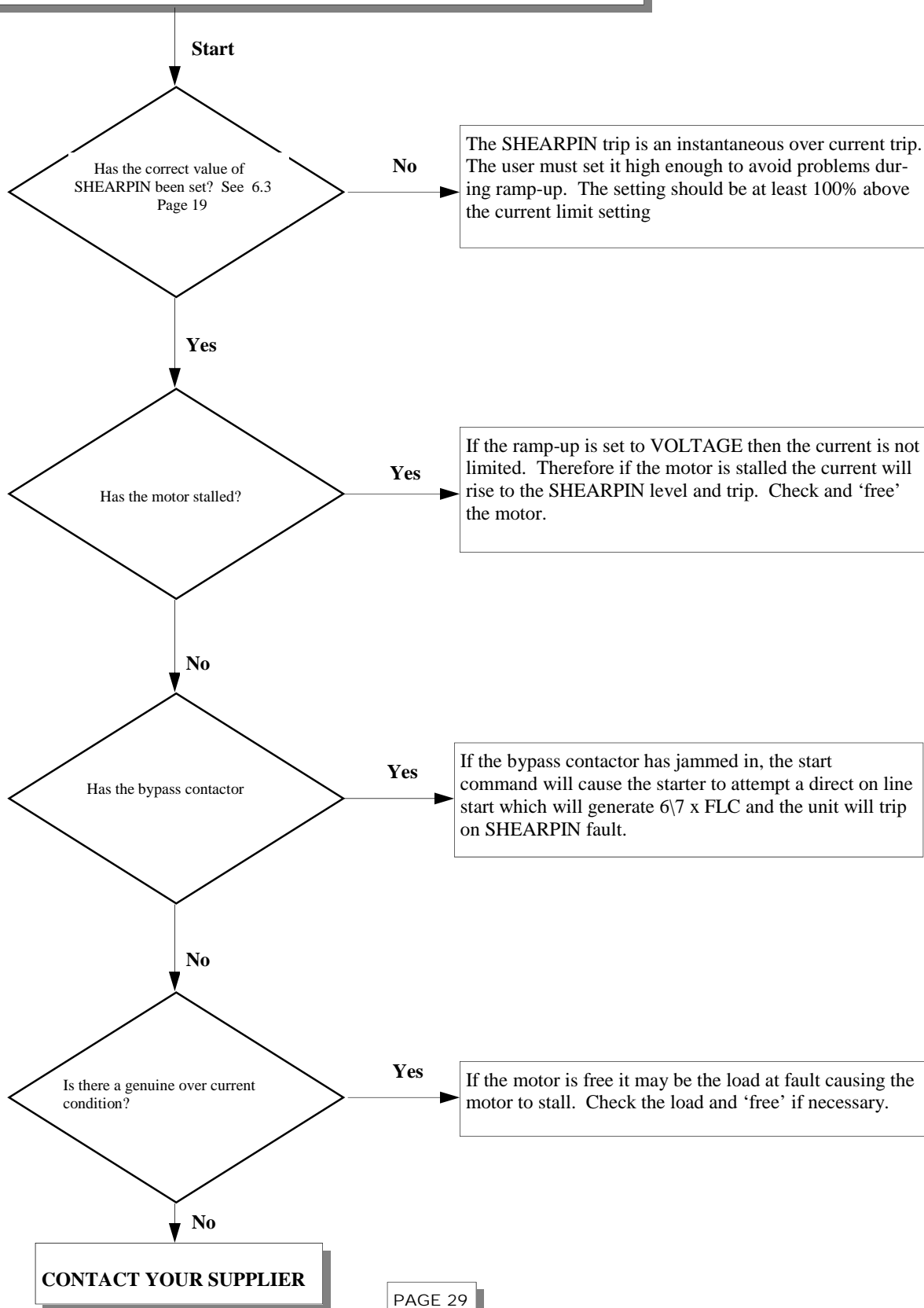

## 10.0 Trouble shooting - continued

### 10.5 The motor does not accelerate properly.

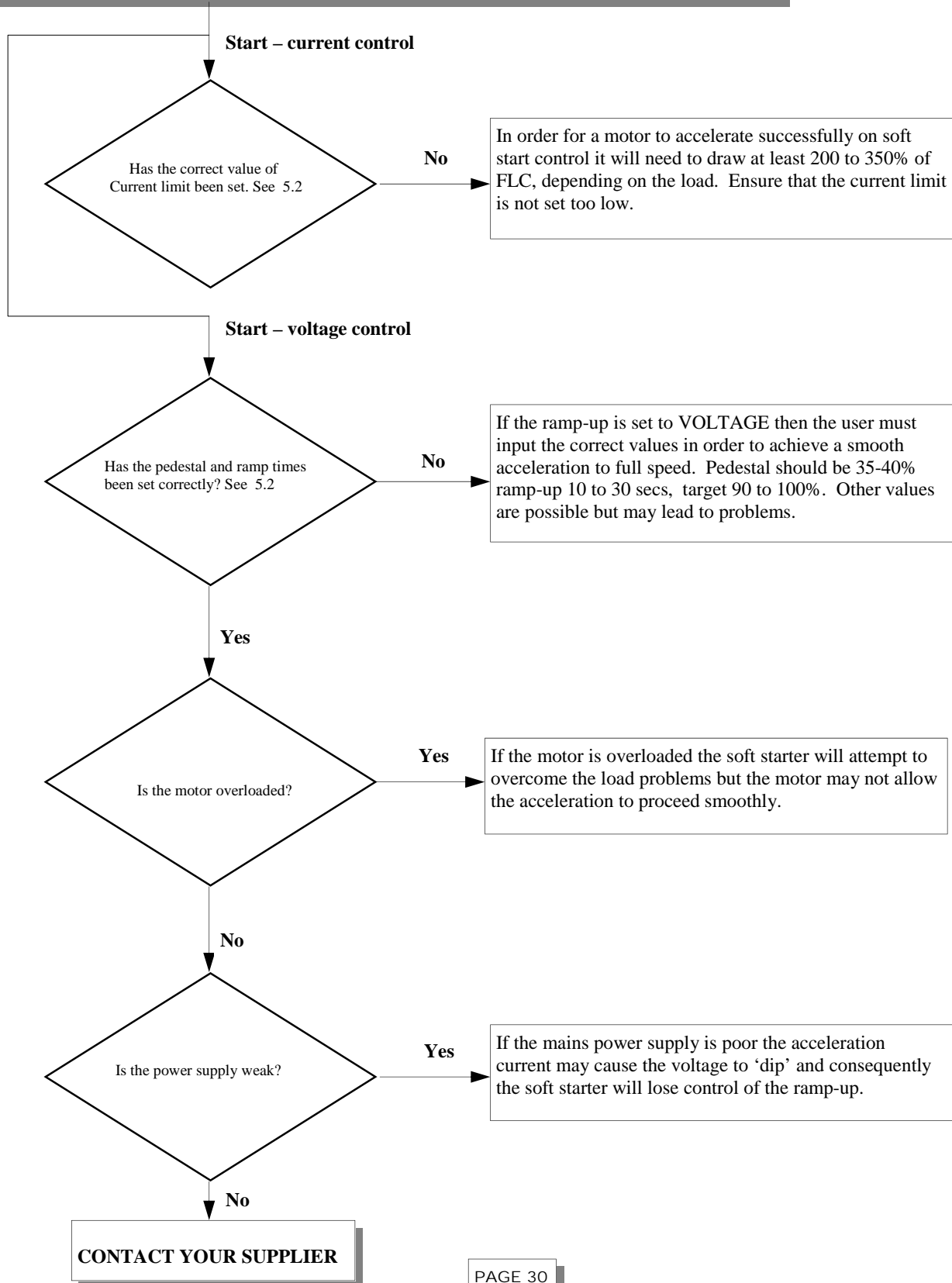

## 10.0 Trouble shooting - continued

### 10.6 The motor does not soft stop properly.

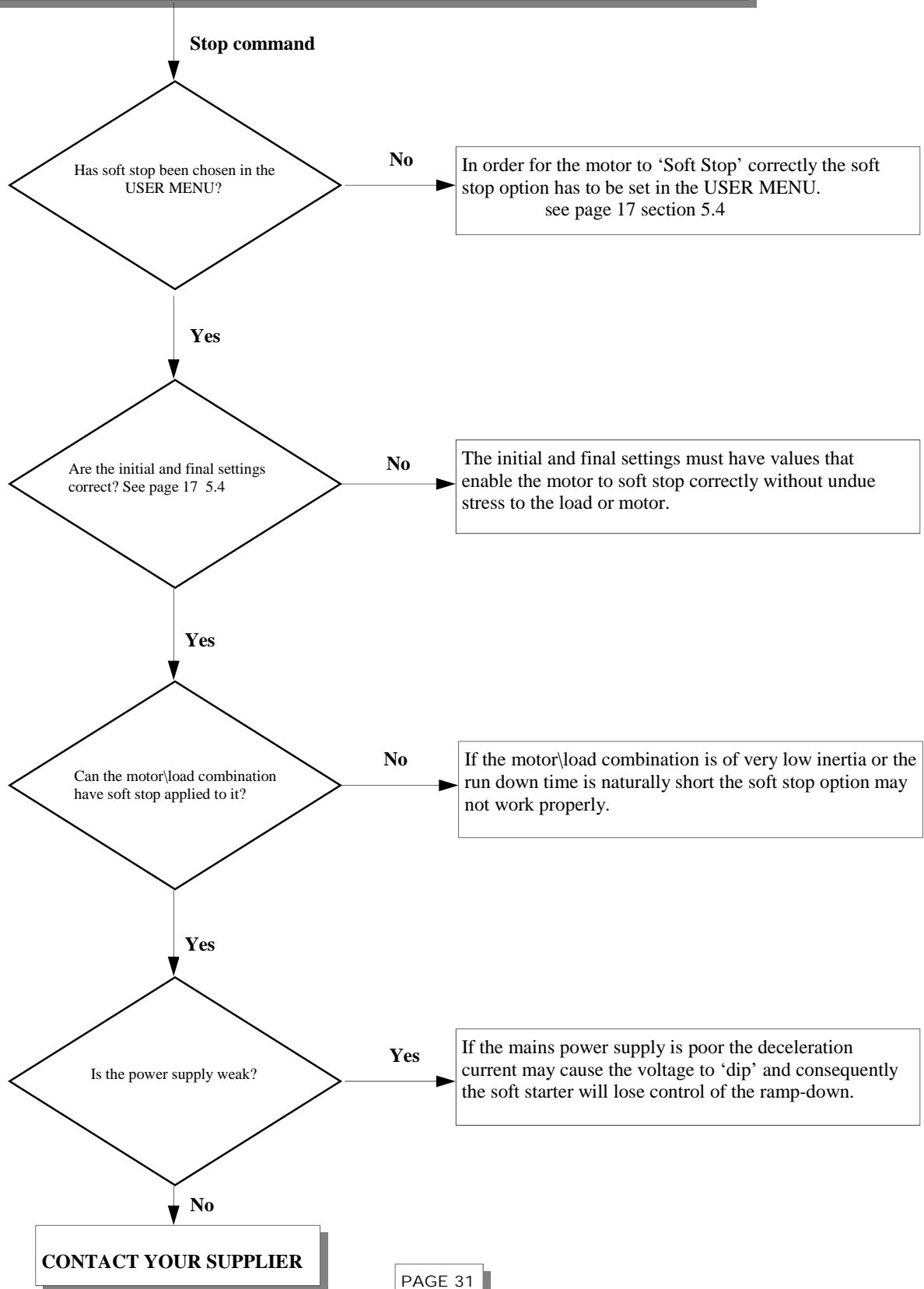

## 10.0 Trouble shooting - continued

### 10.7 The motor does not brake stop properly.

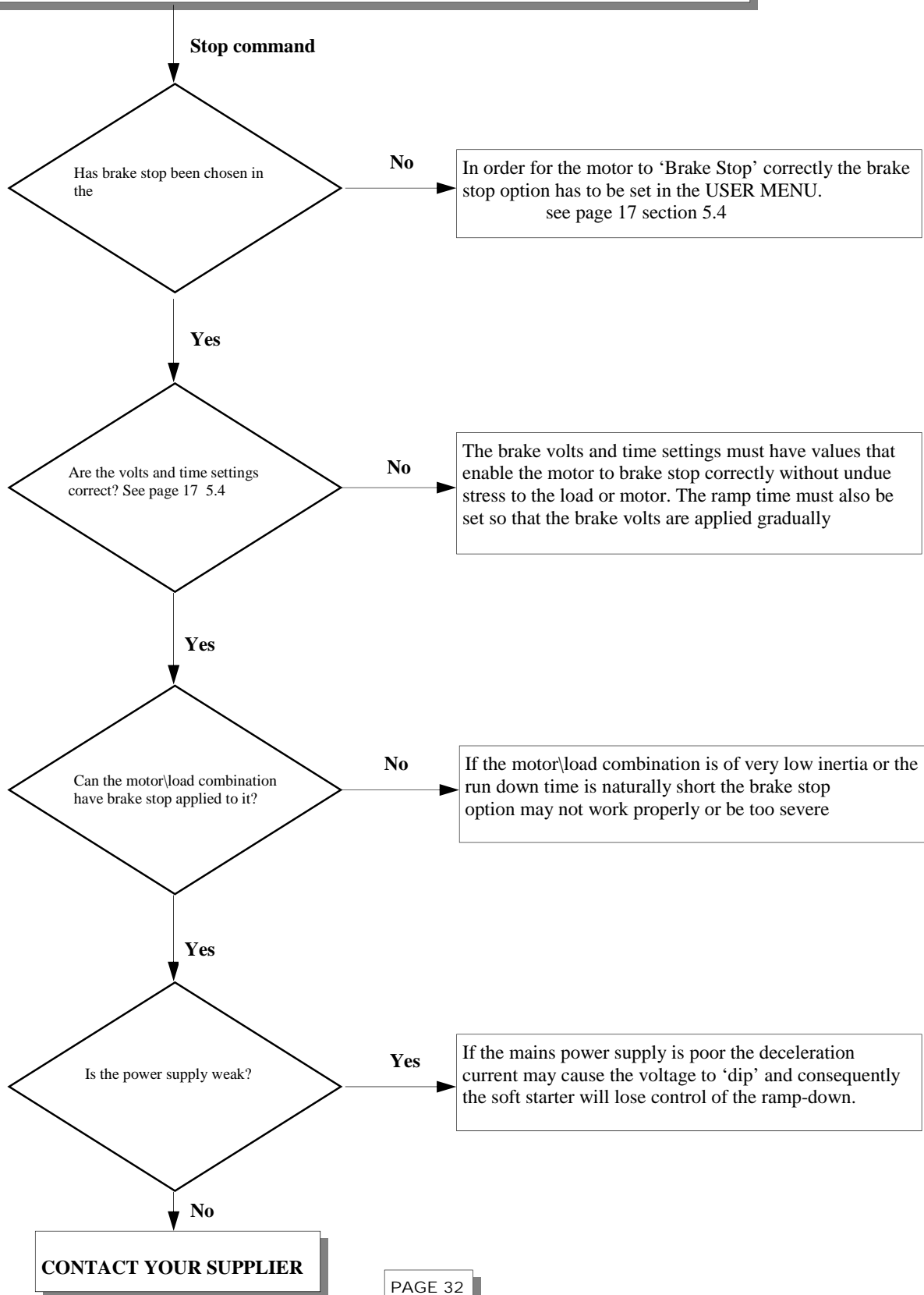

## 11.0 System drawings – index

<b><u>DESCRIPTION</u></b>	<b><u>PAGE</u></b>
BASIC SYSTEM. ISOLATOR, EXTERNAL BYPASS CONTACTOR AND STOP\START PUSHBUTTONS	34
BASIC SYSTEM. ISOLATOR, EXTERNAL BYPASS CONTACTOR AND STOP\START RELAY	34
EMERGENCY STOP SYSTEM. EXTERNAL BYPASS CONTACTOR AND STOP\START BUTTONS	35
EMERGENCY STOP SYSTEM. EXTERNAL BYPASS CONTACTOR AND STOP\START RELAY	35
EMERGENCY STOP SYSTEM. INTEGRATED BYPASS CONTACTOR AND STOP\START BUTTONS	36
EMERGENCY STOP SYSTEM. INTEGRATED BYPASS CONTACTOR AND STOP\ START RELAY	36

Please note that the following drawings are typical and therefore only represent a small part of the overall number of schemes that are possible.

If the user is in any doubt regarding any of the control functions of the TORQ-MASTER soft starter please contact

**RALSPEED'S TECHNICAL SALES DESK @**

TEL 01254 582345 (4 LINES)

FAX 01254 668414

e.mail [technical@ralspeed.com](mailto:technical@ralspeed.com)

Help is also available at our website:

[www.ralspeed.com](http://www.ralspeed.com)

